



Operator's Manual



Liquid Propane Gas (LPG) Grill

Models BTE2614(A,B)LP, BTE3212(A,B)LP & BTE3812BLP

Natural Gas (NG) Grill

Models BTE2614(A,B)NG, BTE3212(A,B)NG & BTE3812BNG

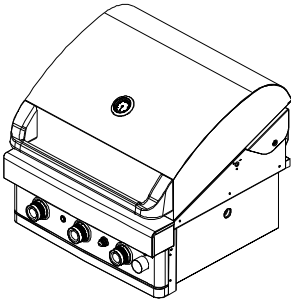

BTE2614BLP/NG

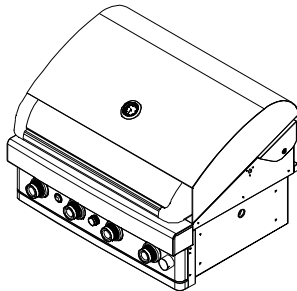

BTE3212BLP/NG

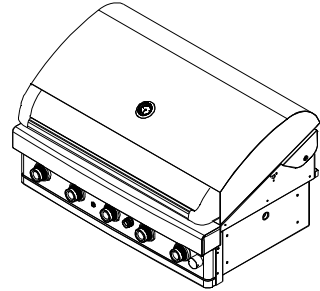

BTE3812BLP/NG

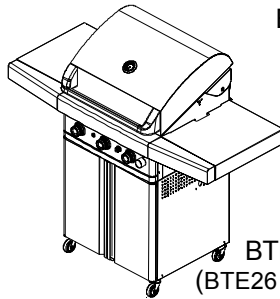

BTE2614ALP/NG
(BTE2614B+UN2614ACT)

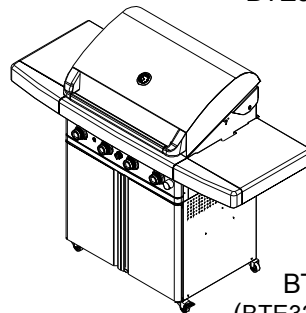

BTE3212ALP/NG
(BTE3212B+UN3212ACT)

FREE HELP FROM THE GRILL EXPERTS

Grand Hall is the expert on this product and trained to help you with:

- Y Assembly Questions
- Y Grill Operation
- Y Replacement of Damaged or Missing parts

visit www.grandhall.com or call:

1-800-474-5587
Monday - Friday 8:00am-4:30pm PST

IMPORTANT:

Y NOTE TO ASSEMBLER/INSTALLER:

Leave this manual with the consumer.

Y NOTE TO CONSUMER:

Keep this manual for future reference.

Y RECORD YOUR SERIAL

(see silver CSA label on main body of grill)



WARNING



- Y Failure to comply with these instructions could result in a fire or explosion that could cause serious bodily injury, death or property damage.
- Y Whether this grill was assembled by you or someone else, you must read this entire manual before using your grill to ensure the grill is properly assembled, installed and maintained.
- Y **Use your grill at least 3 feet away from any wall or surface.** Use your grill at least 3 feet away from combustible objects that can melt or catch fire such as vinyl or wood siding, fences and overhangs or sources of ignition including pilot lights on water heaters and live electrical appliances.
- Y THIS GAS APPLIANCE IS DESIGNED FOR OUTDOOR USE ONLY.
- Y **Never** use your gas grill in a garage, porch, shed, breezeway or any other enclosed area.
- Y **Never** obstruct the flow of ventilation air around your gas grill housing.
- Y **Never** disconnect the gas regulator or any gas fitting while your grill is lit. A lit grill can ignite leaking gas and cause a fire or explosion which could result in property damage, personal injury or death.

Table of Contents

Primary Safety Warnings.....	1-3
Pre-Assembly Instructions.....	3
Part Diagrams and Lists.....	4-14
Assembly Instructions.....	15-18
Use & Care Instructions:	
• Gas Safety and Leak Tests.....	19-21
• Natural Gas Connection.....	22
• Lighting Instructions and Light Operation.....	23
• Troubleshooting.....	24
• Rotisserie Instruction.....	25-27
Cleaning and Maintenance	28-29
Cooking Guide.....	A1-A4
Frequently Asked Questions	A5-A6
Warranty.....	Back Cover

WARNING

- This appliance, when installed, must be electrically grounded in accordance with local codes or, in the absence of local codes, with the *National Electrical Code, ANSI/NFPA 70*, or the *Canadian Electrical Code, CSA C22.1*.
- Keep any electrical supply cord and the fuel supply hose away from any heated surfaces.

DANGER

If you smell gas:

1. Shut off gas to the appliance.
2. Extinguish any open flame.
3. Open lid.
4. If odor continues, keep away from the appliance and immediately call your gas supplier or your fire department.

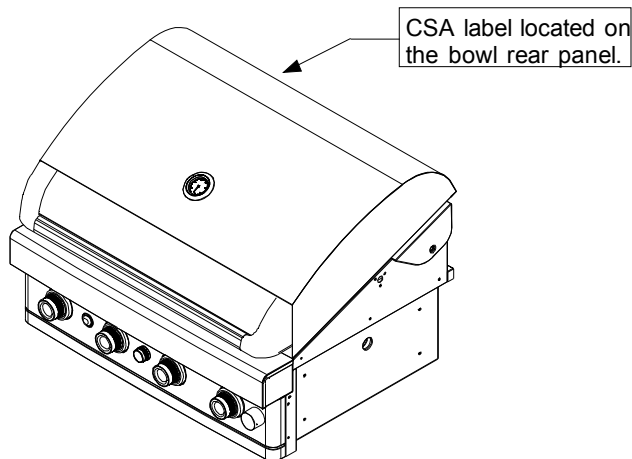

WARNING

1. Do not store or use gasoline or other flammable liquids or vapors in the vicinity of this or any other appliances.
2. An LP cylinder not connected for use shall not be stored in the vicinity of this or any other appliance.

WARNING

- LPG models must be used with Liquid Propane Gas and the regulator assembly supplied. Natural Gas models must be used with Natural Gas only. Any attempt to convert the grill from one fuel type to another is extremely hazardous and will void the warranty.
- Keep gas regulator hose away from hot grill surfaces and dripping grease. Avoid unnecessary twisting of hose. Visually inspect hose prior to each use for cuts, cracks, excessive wear or other damage. If the hose appears damaged do not use the gas grill. Call **1-800-474-5587** for a certified replacement hose.
- **California Proposition 65**
Combustion byproducts produced when using this product contain chemicals known to the State of California to cause cancer, birth defects, or other reproductive harm.

Brass components on the grill, such as hose fittings, propane cylinder valves (sold separately) and burner valve stems, contain lead which is known to the State of California to cause cancer, birth defects, or other reproductive harm.
- **Never use charcoal** or lighter fluid in this gas grill. Failure to comply with these instructions could result in a grease fire or explosion that could cause serious bodily injury, death or property damage.
- **Before each use of your grill:** Inspect the Grease Tray, Grease Tray Heat Shield and inside of the Grill Bowl to be sure there is no excessive grease and debris buildup. Clean the Grease Tray, Grease Tray Heat Shield and inside of the Grill Bowl frequently to eliminate grease/debris build-up and to prevent grease fires. **Failure to comply with these instructions could result in a grease fire and even a subsequent explosion that could cause serious bodily injury, death or property damage.**

WARNING

Never cover or wrap the Cooking Grids, bottom of the Grill Bowl, Grease Tray with aluminum foil or any other material that will absorb grease.

Pre-Assembly Instructions For Your Safety



CAUTION

Failure to comply with these instructions may result in a hazardous situation which, if not avoided, may result in injury.

Spiders and small insects can spin webs and nest in the grill Burner Tubes during transit and warehousing which can lead to a gas flow obstruction resulting in a fire in and around the Burner Tubes. This type of "FLASHBACK FIRE" can cause serious grill damage and create an unsafe operating condition for the user.

To reduce the chance of FLASHBACK FIRE you must clean the Burner Tubes as follows before initial use. Also do this at least once a month in summer and fall or whenever spiders are active in your area, and if your grill has not been used for an extended period of time.

1. Remove the screws from the rear of each Main Burner using a Phillips head screwdriver or wrench.
2. Carefully lift each Burner up and away from the Gas Valve Orifice.
3. Check and clean Burner/Venturi Tubes for insects and insect nests. A clogged tube can lead to a fire beneath the grill.
4. Refer to the figure below and perform one of these 3 cleaning methods:

- METHOD 1:** Bend a stiff wire or wire coat hanger into a small hook as shown and run the hook through the Burner Tube and inside the Burner several times to remove debris.



TO CLEAN BURNER TUBE,
INSERT HOOK
HERE

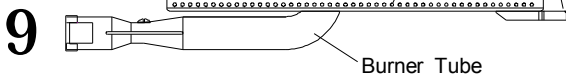

- METHOD 2:** Use a bottle brush with a flexible handle and run the brush through the Burner Tube and inside the Burner several times to remove any debris.
- METHOD 3:** Use an air hose to force air through each Burner Tube. The forced air should pass debris or obstructions through the Burner and out the Ports.

For safe operation ensure the Gas Valve Assembly Orifice is inside the Burner Tube before using your grill. (See figure). If the Orifice is not inside the Burner Tube, lighting the Burner may cause explosion and/or fire resulting in serious bodily injury and/or property damage.

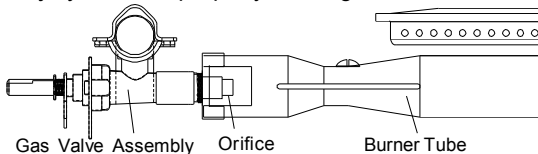

PRE-ASSEMBLY

Read and perform the following pre-assembly instructions:

- Tools Required for Assembly:**
- protective work gloves
 - protective eyewear
 - Phillips head screwdriver
- You will need assistance from another person to handle the grill head and other large, heavy parts.
- Open lid of shipping carton. Remove top sheet of cardboard and packing materials. Lay cardboard sheet on floor and use as a work surface to protect floor and grill parts from scratches.
- You may slice the carton front corners with a utility knife to lay open the carton front panel. This allows you to raise the Lid and remove the components packed inside, making it easier to lift.
- Use the Hardware and Part Diagrams to ensure all items are included and free of damage.
- Do not throw away the bags of hardware that are included with boxed parts. These are required for assembly.
- Do not assemble or operate the grill if it appears damaged. If there are damaged or missing parts when you unpack the shipping box or you have questions during the assembly process call **1-800-474-5587** M-F 8AM-4:30PM PST for assistance.

Grill Installation Codes

The installation must conform with local codes or, in the absence of local codes, with either the National Fuel Gas Code, ANSI Z223.1/NFPA 54, Natural Gas and Propane Installation Code, CSA B149.1, or Propane Storage and Handling Code, B149.2.

WARNING: Grease can get very hot. Always handle the Grease Tray with a flame retardant BBQ mitt. Before removing the Tray, always be sure that the grill has properly cooled. Be aware that the Tray does contain grease and be extremely careful when removing the Tray to prevent spillage. Failure to follow these instructions could cause serious bodily injury or property damage.



CAUTION

When using electrical appliances, basic safety precautions should always be used.

Hardware Parts List for Models BTE2614BLP/NG & BTE3212BLP/NG & BTE3812BLP/NG

PART #	PART DESCRIPTION	QTY	PURPOSE OF PART
P06013018C	Hardware Pack	1	For use in assembly of Model BTE2614B, BTE3212B, BTE3812B, BTH3214B, BTH2614B
S182G03061	Pan Head Screw 3/16" x 3/8"	2	Install the Transformer Bracket(BTE3212B, BTE3812B Only)
S182G03061	Pan Head Screw 3/16" x 3/8"	2	Install the Bracket with LP Regulator (LPG Model Only)
S182G03061	Pan Head Screw 3/16" x 3/8"	3	Install the Tank Tray Set onto the Bottom Panel (LPG Model Only)
S313G0306B	AA Battery	1	

Hardware Diagram for Models BTE2614BLP/NG & BTE3212BLP/NG & BTE3812BLP/NG



Pan Head Screw 3/16"x3/8"
 Part # S182G03061
 Qty. 7 (For Models BTE3212BLP & BTE3812BLP)
 Qty. 2 (For Models BTE2614BNG, BTE3212BNG & BTE3812BNG)
 Qty. 5 (For Models BTE2614BLP)

*One AA Battery included in the Hardware Pack

Parts Diagram for Models BTE2614BLP & BTE2614BNG

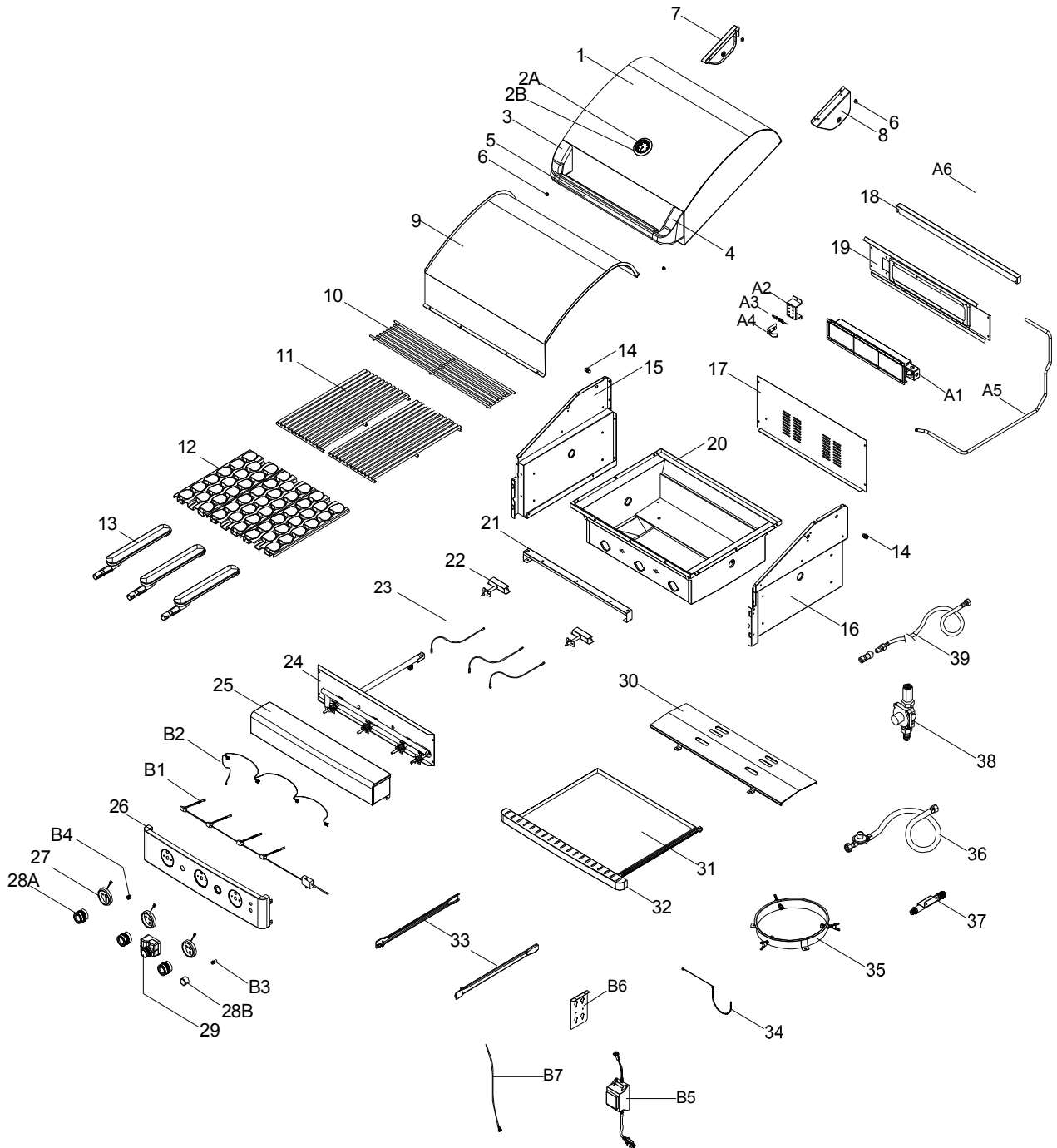

Parts List for Models BTE2614BLP & BTE2614BNG

KEY	DESCRIPTION	PART#	QTY.
1	Lid Assembly	P0014633AA	1
2A	Temperature Gauge	P00601551A	1
2B	Temperature Gauge Seat	P00614031A	1
3	Lid Handle Bracket, Left	P00307052E	1
4	Lid Handle Bracket, Right	P00308052E	1
5	Lid Handle	P00215041H	1
6	Protective Pad	P05518002I	4
7	Lid Assembly Bracket, Left	P03320007C	1
8	Lid Assembly Bracket, Right	P03320008C	1
9	Lid Trim Plate	P0014635K4	1
10	Warming Rack	P01514022B	1
11	Cooking Grid 13"	P01606036B	2
12	Flame Tamer with Ceramic	P01720041A	3
13	Burner/Main	P02003049B	3
14	Lid Hinge with Nut	P05501136L	2
15	Bowl Side Panel, Left	P0076124EC	1
16	Bowl Side Panel, Right	P0076224EC	1
17	Bowl Side Panel, Rear/Lower	P0073743BC	1
18	Trim Panel, Rear	P07515030A	1
19	Bowl Side Panel, Rear/Upper	P0075822BC	1
20	Grill Bowl Assembly	P00771136C	1
21	Burner Bracket	P02208047A	1
22	Gas Collector Box with Electrode	P02608059C	2
23	Electric Wires Set	P02615188A	1
24	Gas Valve/Manifold Assembly (LPG)	Y0060833	1
	Gas Valve/Manifold Assembly (NG)	Y0060834	1
25	Bowl Front Trim Plate Assembly	P02917011S	1
26	Control Panel	P02913993S	1
27	Control Knob Seat with LED light	P03415314A	3
28A	Control Knob for Main Burner	P03435025U	3
28B	Control Knob for Back Burner	P03418245U	1
29	Electric Ignitor, 4-Port	P02502384C	1
30	Grease Tray Heat Shield	P06904063C	1
31	Grease Tray	P02717923C	1
32	Grease Tray Handle	P0272017CC	1
33	Grease Tray Slide Set	P05516140M	1
34	Lighting Stick	P05507140M	1
35	Tank Tray Set (LPG)	Y0340055	1
36	Regulator with Hose(LPG)	P03635005A	1
37	Regulator Hose Connector (LPG)	P03901056C	1
38	Regulator NG	P03614005C	1
39	Hose, 12 FT (NG), 3/8" ID(sold separately)	P03703001A	1

Parts List for Models BTE2614BLP & BTE2614BNG

KEY	DESCRIPTION	PART#	QTY.
A1	Back Burner Assembly (LPG)	Y0030028	1
	Back Burner Assembly (NG)	Y0030029	
A2	Back Burner Thermocouple Protector	P03328050C	1
A3	Thermocouple for Back Burner	P05305072B	1
A4	Back Burner Electrode	P02614015C	1
A5	Back Burner Extension Tube	P03701011A	1
A6	Back Burner Wind Shield(LPG)	P06906103C	1
	Back Burner Wind Shield(NG)	P06906104C	1
B1	LED Rectifier with Wire Assembly	P05383018B	1
B2	Electric Wires Set	P02627020A	1
B3	LED Light for Back Burner	P05373010B	1
B4	Switch for Light	P05360004B	1
B5	Transformer	P05374015B	1
B6	Transformer Bracket	P03328057A	1
B7	Transformer Connecting Wire	P05352025B 	1
	Rotisserie Assembly	Y0250214	1
	Hardware Pack	P06013018C	1
	Operator's Manual	P80151141D	1

Parts Diagram for Models BTE3212BLP & BTE3212BNG

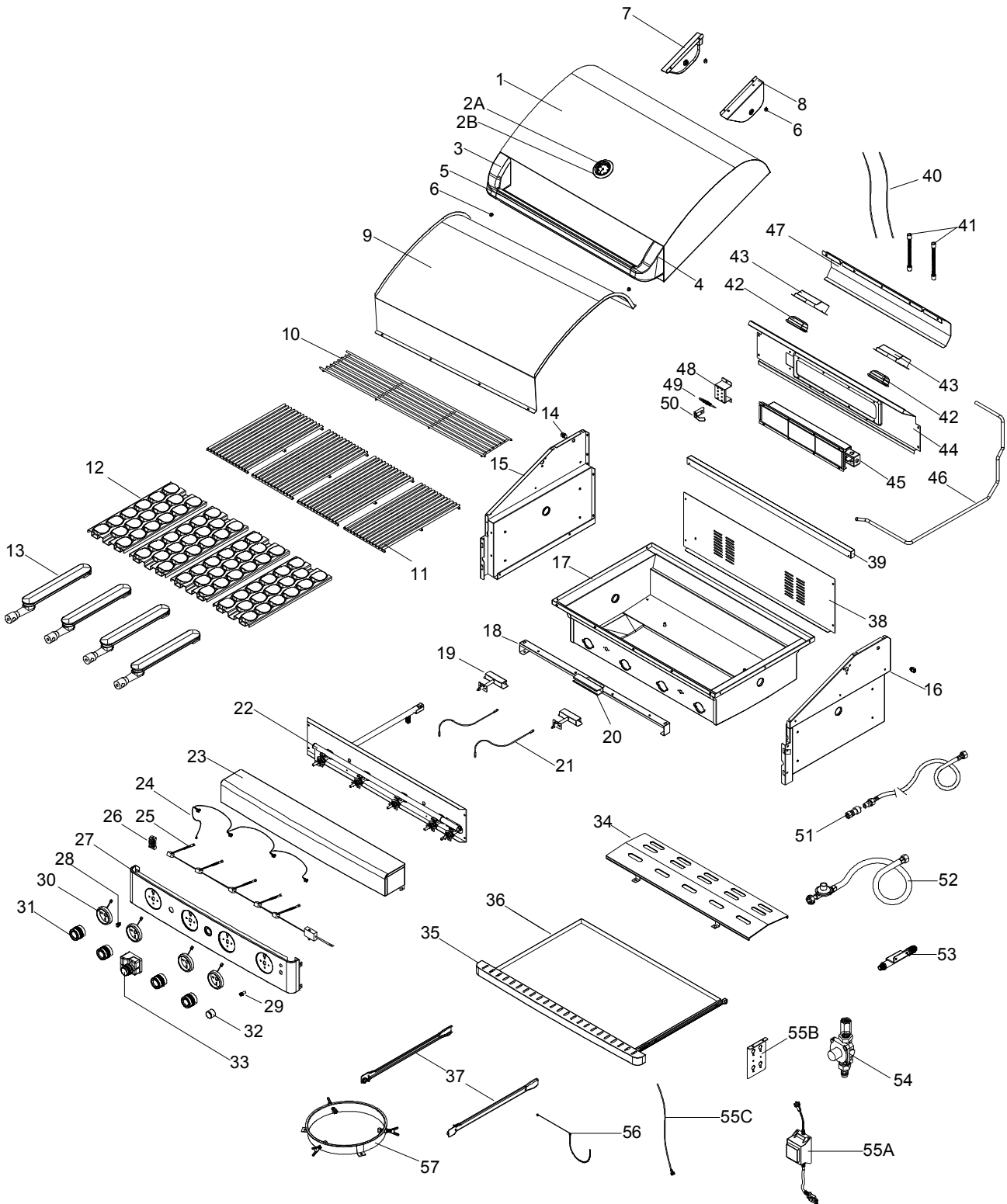

Parts List for Models BTE3212BLP & BTE3212BNG

KEY	DESCRIPTION	PART#	QTY.
1	Lid Assembly	P0014748AA	1
2A	Temperature Gauge	P00601551A	1
2B	Temperature Gauge Seat	P00614031A	1
3	Lid Handle Bracket, Left	P00307052E	1
4	Lid Handle Bracket, Right	P00308052E	1
5	Lid Handle	P00215039H	1
6	Protective Pad	P05518002I	4
7	Lid Assembly Bracket, Left	P03320007C	1
8	Lid Assembly Bracket, Right	P03320008C	1
9	Lid Trim Plate	P0014735K4	1
10	Warming Rack	P01516028B	1
11	Cooking Grid W8"	P01606037B	4
12	Flame Tamer with Ceramic	P01720041A	4
13	Burner/Main	P02003049B	4
14	Lid Hinge with Nut	P05501136L	2
15	Bowl Side Panel, Left	P0076124EC	1
16	Bowl Side Panel, Right	P0076224EC	1
17	Grill Bowl Assembly	P00713996C	1
18	Burner Bracket	P02204357A	1
19	Gas Collector Box with Electrode	P02608059C	2
20	Crosslight Channel	P02212405A	1
21	Electric Wires Set/Electrode	P02615188A	1
22	Gas Valve/Manifold Assembly (LPG)	Y0060793	1
	Gas Valve/Manifold Assembly (NG)	Y0060794	1
23	Bowl Front Trim Plate Assembly	P02915781S	1
24	Electric Wires Set	P02627018A	1
25	LED Rectifier with Wire Assembly	P05383011B	1
26	Terminal Collector	P05336007E	1
27	Control Panel	P02915793S	1
28	Switch for Lamp	P05360003B	1
29	LED Light for Back Burner	P05373010B	1
30	Control Knob Seat with LED Light	P03415314A	4
31	Control Knob for Main Burner	P03435025U	4
32	Control Knob for Back Burner	P03418245U	1
33	Electric Ignitor, 4-Port	P02502384C	1
34	Grease Tray Heat Shield	P06904059C	1
35	Grease Tray Handle	P0272018CC	1
36	Grease Tray	P02717933C	1
37	Grease Tray Slide Set	P05516140M	2
38	Bowl Panel, Rear/Lower	P0073740BC	1
39	Trim Panel, Rear	P07515027A	1
40	Lamp Wire Set	P05352022B	1

Parts List for Models BTE3212BLP & BTE3212BNG

KEY	DESCRIPTION	PART#	QTY.
41	Lamp Wire Set Protector	P05533011A	2
42	Lamp,12V, 10W	P05352012B	2
43	Lamp Cover	P05352013E	2
44	Back Burner Frame	P02011075B	1
45	Back Burner Assembly (LPG)	Y0030028	1
	Back Burner Assembly (NG)	Y0030029	1
46	Back Burner Extension Tube	P03701011A	1
47	Back Burner Cover(LPG)	P06906099C	1
	Back Burner Cover(NG)	P06906105C	1
48	Back Burner Thermocouple Protector	P03328050C	1
49	Thermocouple for Back Burner	P05305072B	1
50	Back Burner Electrode	P02614015C	1
51	Hose, 12 FT. NG (Sold Separately)	P03703001A	1
52	Regulator with Hose(LPG)	P03635005A	1
53	Regulator Hose Connector (LPG)	P03901056C	1
54	Regulator Assembly (NG)	P03614005C	1
55A	Transformer	P05374015B	1
55B	Transformer Bracket(For Build-in Model Only)	P03328057A	1
55C	Transformer Connecting Wire	P05352023B	1
56	Lighting Stick	P05507140M	1
57	Tank Tray Set (LPG) (For Build-in Model Only)	Y0340055	1
	Rotisserie Assembly	Y0250206	1
	Hardware Pack	P06013018C	1
	Operator's Manual	P80151141D	1

Parts Diagram for Model BTE3812BLP & BTE3812BNG

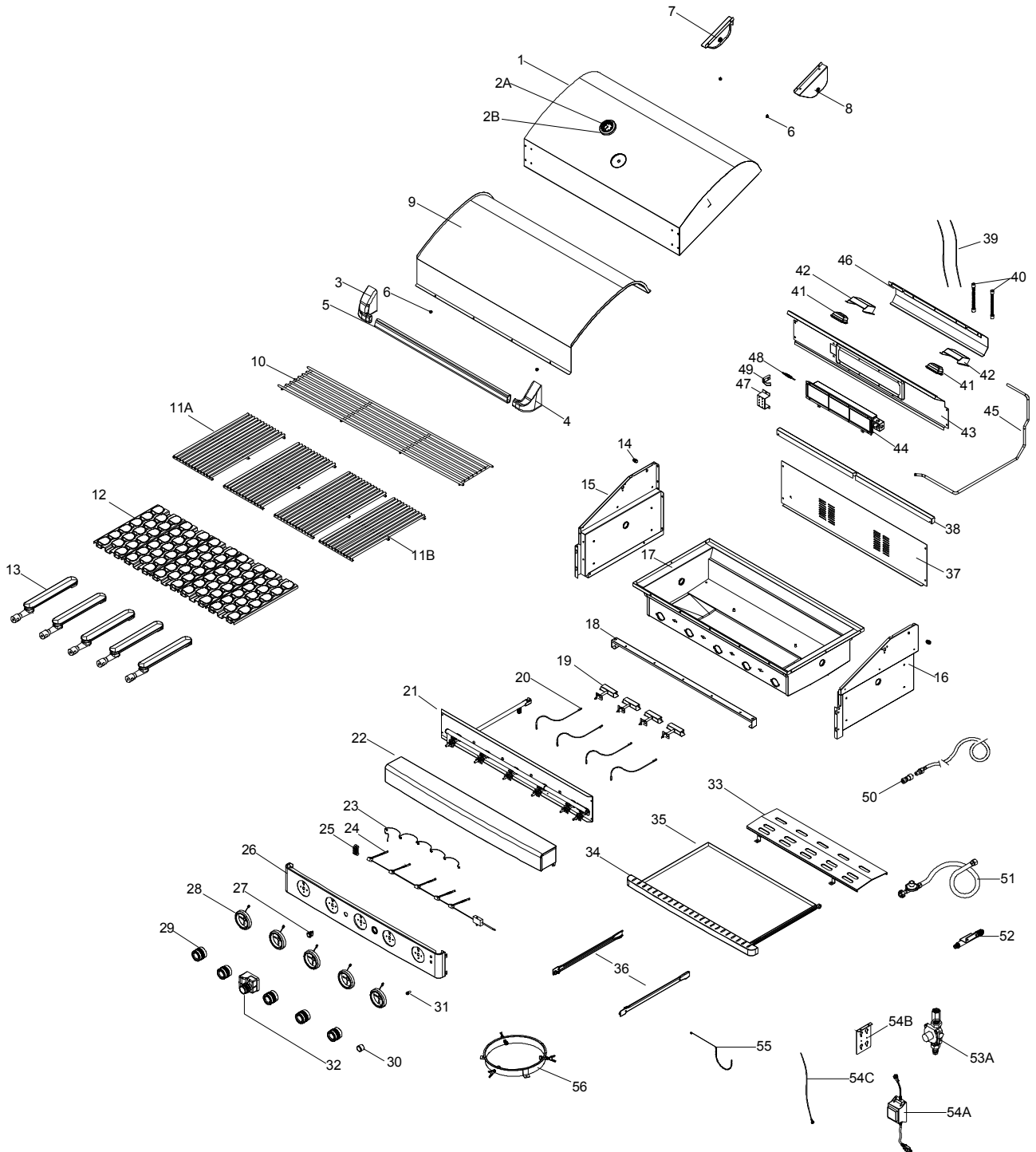

Parts List for Model BTE3812BLP & BTE3812BNG

KEY	DESCRIPTION	PART#	QTY.
1	Lid Assembly	P0011979AA	1
2A	Temperature Gauge	P00601551A	1
2B	Temperature Gauge Seat	P00614031A	1
3	Lid Handle Bracket, Left	P00307052E	1
4	Lid Handle Bracket, Right	P00308052E	1
5	Lid Handle	P00215040H	1
6	Protective Pad	P05518002I	4
7	Lid Assembly Bracket, Left	P03320007C	1
8	Lid Assembly Bracket, Right	P03320008C	1
9	Lid Trim Plate	P0011980K4	1
10	Warming Rack	P01517007B	1
11A	Cooking Grid W255	P016050056	3
11B	Cooking Grid W217	P016050066	1
12	Flame Tamer with Ceramic	P01720041A	5
13	Burner	P02003049B	5
14	Lid Hinge with Nut	P05501136L	2
15	Bowl Side Panel, Left	P0076124EC	1
16	Bowl Side Panel, Right	P0076224EC	1
17	Grill Bowl Assembly	P00769016C	1
18	Burner Bracket	P02210057A	1
19	Gas Collector Box with Electrode	P02608059C	4
20	Electric Wires Set/Electrode	P02615189A	1
21	Gas Valve/Manifold Assembly (LPG)	Y0060795	1
	Gas Valve/Manifold Assembly (NG)	Y0060796	1
22	Bowl Front Trim Plate Assembly	P02916061S	1
23	Electric Wires Set	P02627019A	1
24	LED Rectifier with Wire Assembly	P05383012B	1
25	Terminal Collector	P05336007E	1
26	Control Panel	P02916073S	1
27	Switch for Lamp	P05360003B	1
28	Control Knob Seat with LED Light	P03415314A	5
29	Control Knob for Main Burner	P03435025U	5
30	Control Knob for Back Burner	P03418245U	1
31	LED Light for Back Burner	P05373010B	1
32	Electric Ignitor, 6-Port	P02502305C	1
33	Grease Tray Heat Shield	P06904060C	1
34	Grease Tray Handle	P0272019CC	1
35	Grease Tray	P02717943C	1
36	Grease Tray Slide Set	P05516140M	2
37	Bowl Panel, Rear/Lower	P0073752BC	1
38	Trim Panel, Rear	P07515028R	1
39	Lamp Wire Set	P05352022B	1
40	Lamp Wire Set Protector	P05533011A	2
41	Lamp, 12V, 10W	P05352012B	2

Parts List for Model BTE3812BLP & BTE3812BNG

KEY	DESCRIPTION	PART#	QTY.
42	Lamp Cover	P05352013E	2
43	Back Burner Frame	P02011076B	1
44	Back Burner Assembly (LPG)	Y0030028	1
	Back Burner Assembly (NG)	Y0030029	1
45	Back Burner Extension Tube	P03701011A	1
46	Back Burner Cover (LPG)	P06906100C	1
	Back Burner Cover (NG)	P06906106C	1
47	Thermocouple Protector	P03328050C	1
48	Thermocouple for Back Burner	P05305072B	1
49	Back Burner Electrode	P02614015C	1
50	Hose, 12 FT. NG (Sold Separately)	P03703001A	1
51	Regulator with Hose (LPG)	P03635005A	1
52	Regulator Hose Connector (LPG)	P03901056C	1
53	Regulator with Hose (NG)	P03614005C	1
54A	Transformer	P05374015B	1
54B	Transformer Bracket	P03328057A	1
54C	Transformer Connecting Wire	P05352023B	1
55	Lighting Stick	P05507140M	1
56	Tank Tray Set (LPG)	Y0340055	1
	Rotisserie Assembly	Y0250207	1
	Hardware Pack	P06013018C	1
	Operator's Manual	P80151141D	1

For the repair or replacement parts you need:
Call 1-800-474-5587 M-F 8AM-4:30 PM PST

To obtain the correct replacement parts for your gas grill, please refer to the part numbers in this parts list. The following information is required to ensure you receive the correct parts:

1. Model and Serial Number (see CSA label on grill)
2. Part Number
3. Part Description
4. Quantity of parts needed

Important: Use only Grand Hall replacement parts. The use of any part that is not a Grand Hall replacement part can be dangerous and will also void your product warranty. Keep this Operator's Manual for convenient referral and for part replacement.

Rotisserie Assembly Parts Diagram for BTE2614(A,B)LP/NG, BTE3212(A,B)LP/NG & BTE3812BLP/NG

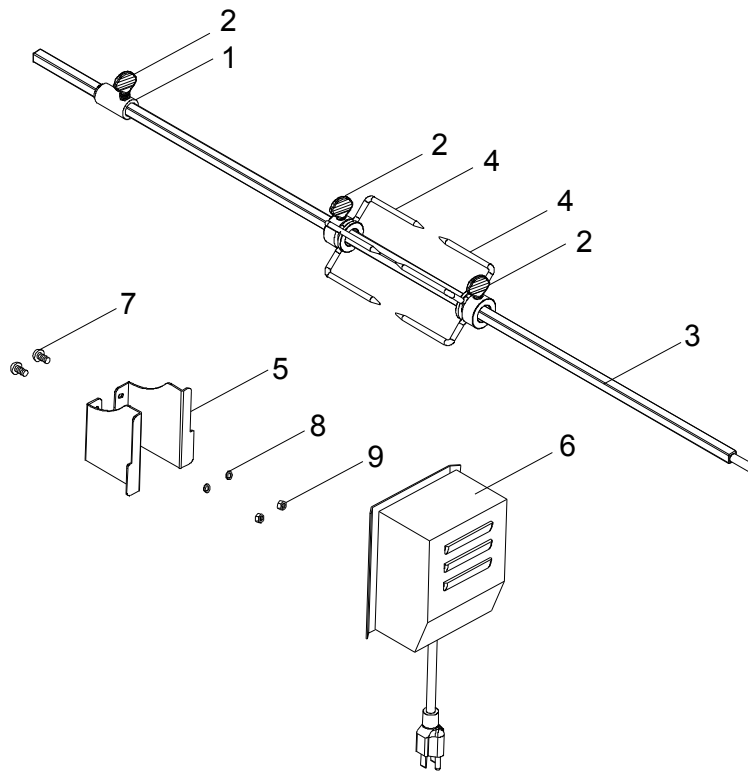

Rotisserie Assembly Parts List for BTE2614(A,B)LP/NG, BTE3212(A,B)LP/NG & BTE3812BLP/NG

KEY	DESCRIPTION	PART#	QTY
1.	Rot. Collar	P05508254A	1
2.	Rot. Thumbscrew 1/4"x1/2"	S196G04081	3
3.	Rot. Spit (for BTE2614(A,B)LP/NG Models)	P05508253A	1
	Rot. Spit (for BTE3212(A,B)LP/NG Models)	P05508230A	1
	Rot. Spit (for BTE3812BLP/NG Models)	P05508231A	1
4.	Rot. Holding Fork	P055082125	2
5.	Rot. Motor Bracket	P03308029C	1
6.	Rot. Motor/AC	P07101039B	1
7.	Rot. Phillips Head Screw 3/16"x1/2" UNC	S112G03081	2
8.	Rot. Washer 3/16"	S411G03061	2
9.	Hex Nut 3/16"	S362G03061	2

Hardware for Rotisserie

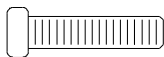

Rotisserie Screw
3/16"x1/2" UNC
Qty. 2
Part # S112G03081

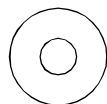

Rotisserie Washer
3/16"
Qty. 2
Part # S411G03061

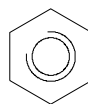

Hex Nut 3/16"
Qty. 2
Part # S362G03061

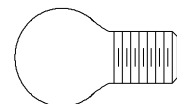

Rotisserie Thumbscrew
1/4"x1/2"
Qty. 3
Part # S196G04081

Customer Service Helpline: If you have questions about assembly or grill operation, or if there are damaged or missing parts when you unpack this unit from the shipping box, call us 8:00 am - 4:30 pm PST, Monday through Friday at 1-800-474-5587

Installation Instructions for Models BTE2614BLP/NG, BTE3212BLP/NG & BTE3812BLP/NG

NOTE: The grill head you purchased is to be installed on the island which is not included in this purchase. You either need to purchase a prebuilt island or you have to build your own island. Before building your grill island, please read the construction guidelines and clearances in **Fig.6** and on **pages 16 & 17** carefully.

CAUTION : Even though it is possible for one person to install this grill, it is better to obtain assistance from another person when handling the large, heavy pieces.

1 Install Grill Head

- With the help of your assistant, lift the grill head and place it into the cutout of your island (See Diagram). The island shown in the diagram is for illustration purpose only. It is not in scale.

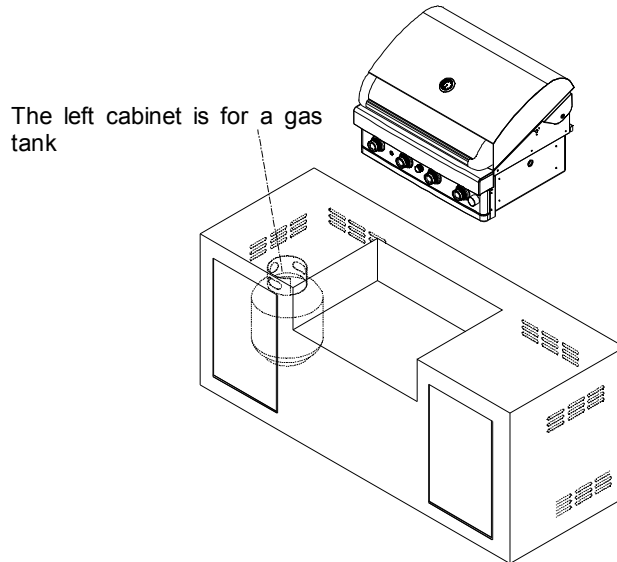

2 Install Transformer. Connect the Transformer to Power Source.

- Install the transformer bracket onto the underside of the right bowl panel using 2 Pan Head Screws 3/16"x3/8" and tighten securely (**See Fig.1**).
- Attach transformer to the transformer bracket by inserting the four stud bolts on the transformer into the four key holes on the transformer bracket. Press the transformer downward until it rests firmly in place. (**See Fig. 2**)
- Insert the transformer-plug into the transformer-socket and tighten securely. (**See Fig.3**)
- Depending on your island construction, you may need to make one hole on your island rear panel. Then pull the transformer cord out through the hole and plug it into a properly grounded 120V AC outlet.
- Note: In case nature gas from the house is used, please continue to step 3. If the gas tank is used, please skip step 3 and go directly to step 4.



Pan Head Screw
3/16"x3/8"
Qty. 2
Part # S182G03061

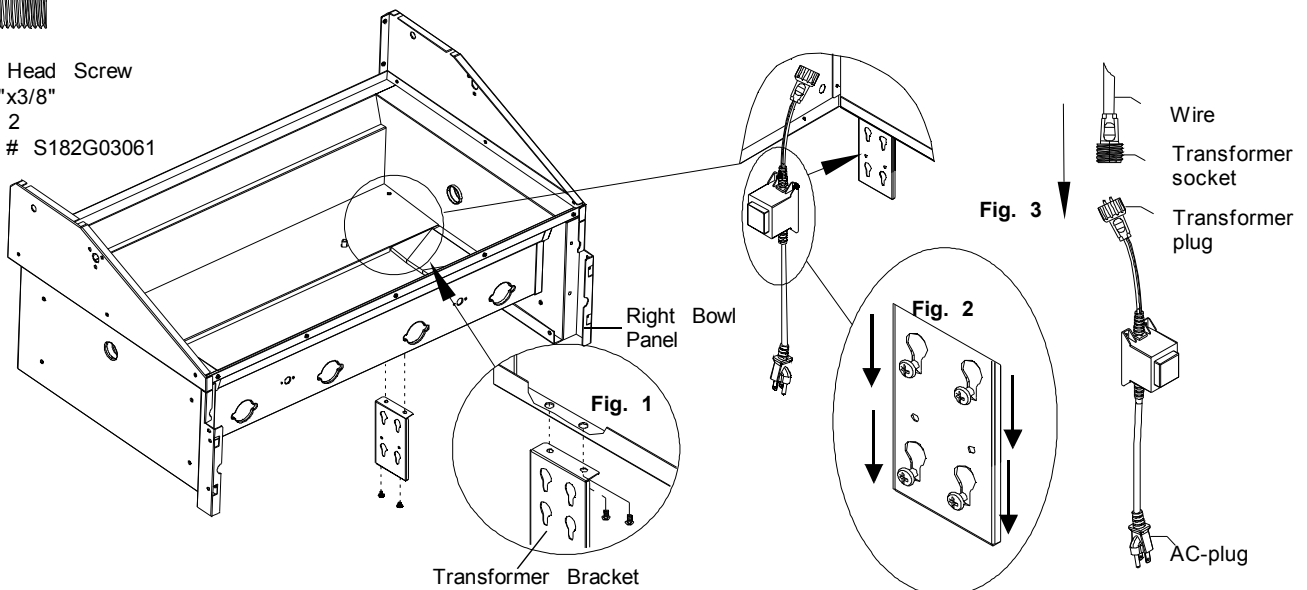

3 Install Natural Gas(NG) Regulator and 12 Foot Hose

- Connect the NG regulator to the inlet of gas manifold. (See Fig. 4)
- Connect the swivel nut of the 12 ft. NG hose to the vertical fitting of the NG Regulator.

WHEN YOU FINISHED THIS STEP, PLEASE SKIP TO STEP 6.

NOTE: Make sure the 12 ft. NG hose stays away from sharp edges.

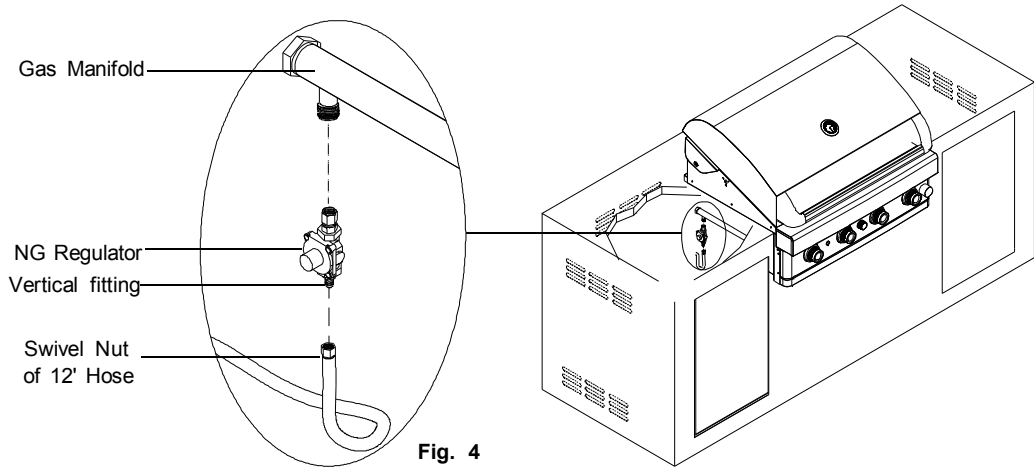

Fig. 4

4 Install Regulator, Tank Tray Set and Liquid Propane(LP) Gas Tank

Note: Regarding the connector, for safety, we suggest use a stainless steel flexible connector. But, if using semi-rigid tubing, do not use materials made of aluminum or aluminum alloy tubing. The connector should be installed at the location visible when opening the door.

- On the proper location, drill 2 holes on the island left side panel for installing the regulator hose connector. Then install the regulator using 2 Pan Head Screws 3/16"x3/8" and tighten securely.
- On the proper location, drill 3 holes on the island left bottom panel for installing the tank tray set. Then install tank tray set using 3 Pan Head Screws 3/16"x3/8" and tighten securely.
- Connect the stainless steel flexible connector to the manifold and regulator, then use a clamp to hold the stainless steel flexible connector as shown for securing.
- Place the LP gas tank into the tank tray set. Make sure the tank valve facing the right rear corner of left island. Tighten the wing bolt to secure the LP gas tank. (See Fig. 5)
- Connect the LP regulator onto the LP gas tank.

CAUTION: There shall be a minimum clearance of 2 inches (50.8 mm) between the floor of the LP-gas cylinder enclosure and the ground.

stainless steel flexible connector (Not provided) must comply with the Standard for connectors for Outdoor Gas Appliances and Manufactured Homes, ANSI Z21.75-CSA 6.27, and suitable for outside installation. The maximum length of the connection shall be 6ft. (1.82m).

clamp (Not provided)

regulator hose connector

5/8" UNF male thread



Pan Head Screw
3/16"x3/8"
Qty. 5
Part # S182G03061

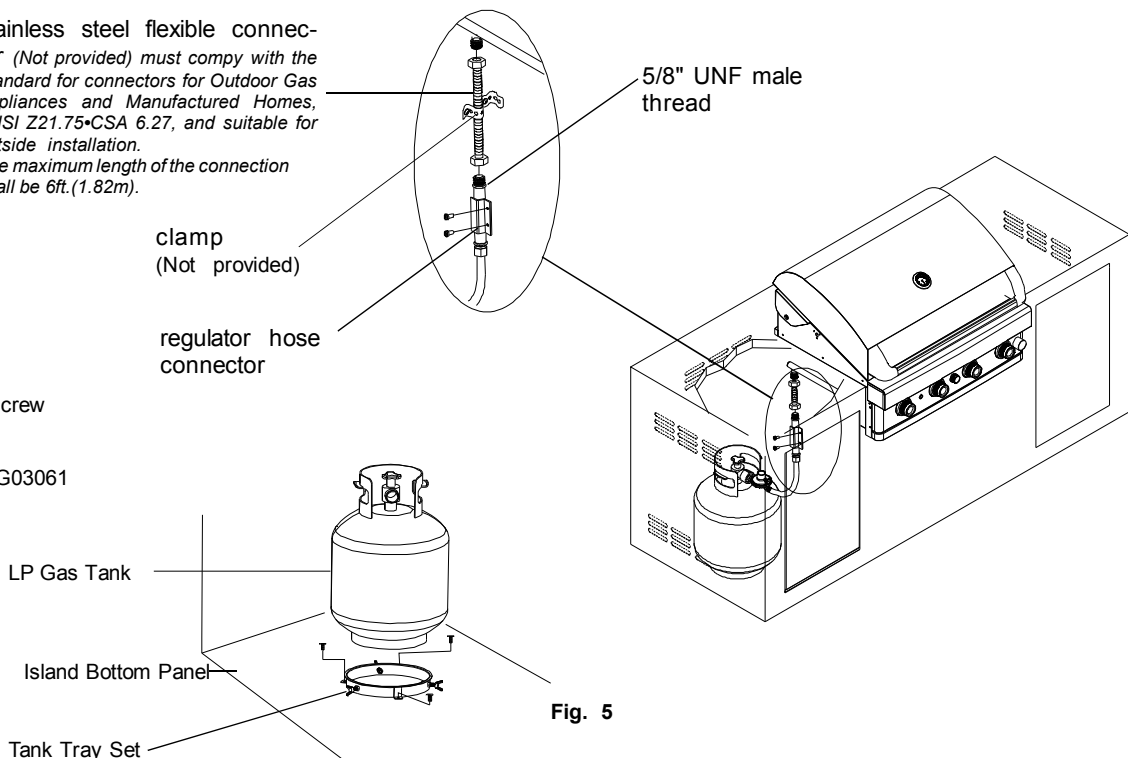

Fig. 5

5 Install Partition Panel

- The gas grill is designed for use with a maximum of 20 lb tank. As per standard, a partition panel (not included) or equivalent device is required to be installed in the left cabinet of the island for preventing the use of 30 lb tank.

Note: Make sure there is 22~24" of clearance between the partition panel and tank tray set. The space around the gas tank is not greater than 12".

Vent Openings must be at least 1/8" wide

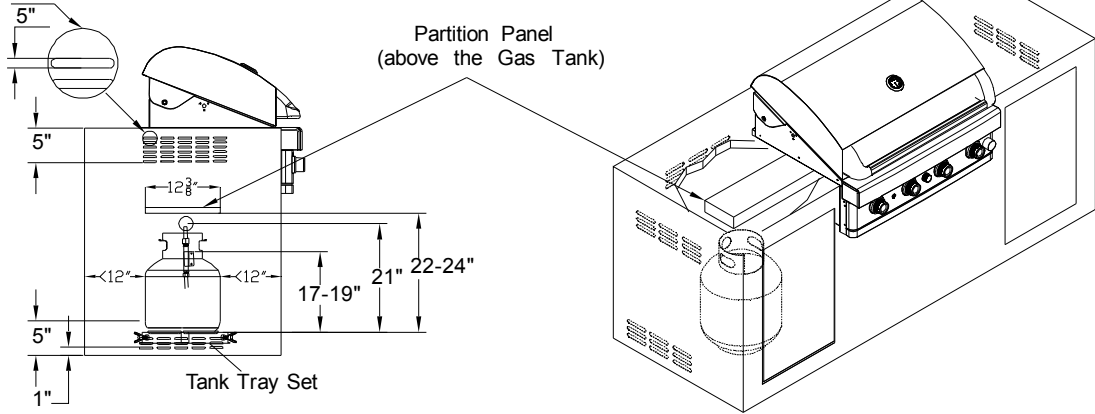
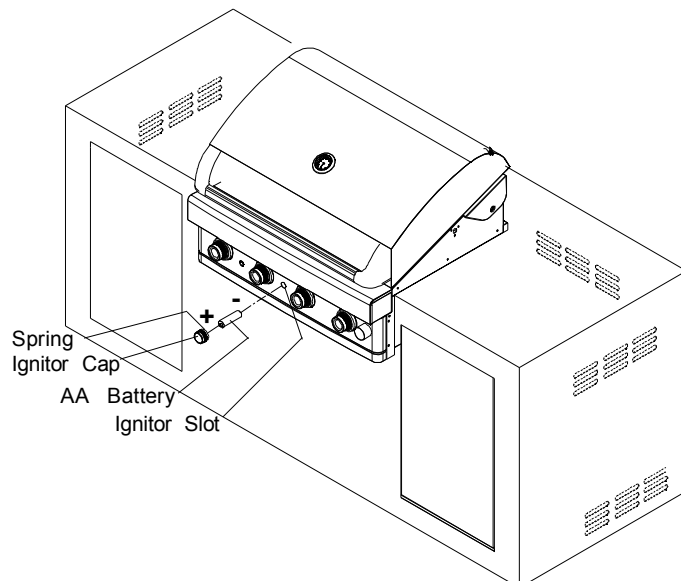

Fig. 6

6 Install Ignitor Battery

- Remove Ignitor Cap from Control Panel.
- Place supplied AA battery into the Ignitor Slot with positive pole facing you.
- Install the Cap and Spring over the AA battery and tighten securely.



7

Main Burner Electrode Check with the assistance of another person, perform this Electrode Check before proceeding.

This test will ensure that the Spark Electrode Tips are properly positioned so your grill lights easily.

- Be sure all control knobs are set to "OFF" and open the grill lid.
- Have your assistant stand to the right of the grill and look toward the front of the grill bowl. **Never** put your face inside the grill head.
- Push and turn burner control knob to  and you will hear a "clicking" sound and your assistant would see a tiny blue spark within each gas collector box. If a spark is present, the electrode tips are properly positioned.
- If no spark is seen, the spark gap needs to be adjusted as follows:
 - If the gap between the spark electrode tip and receiver is more than 3/16" wide use needle nose pliers to gently squeeze the gas collector box to narrow gap.
 - Recheck the electrode again, if no "clicking" sound is heard:
- AA Battery may be installed backwards.
- Electric wires may be loose. Remove the AA Battery and inspect the Ignitor Junction Box found behind the Control Panel and reconnect any loose wires.

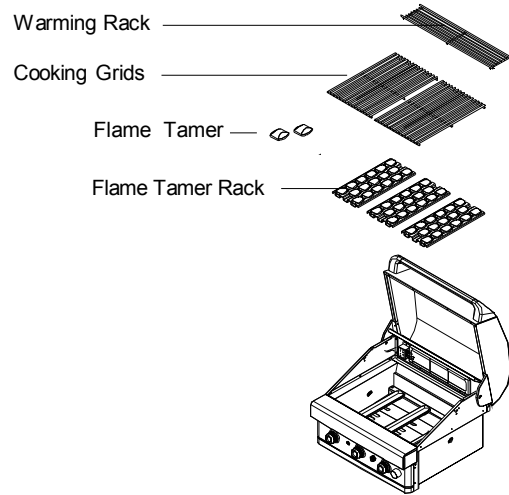
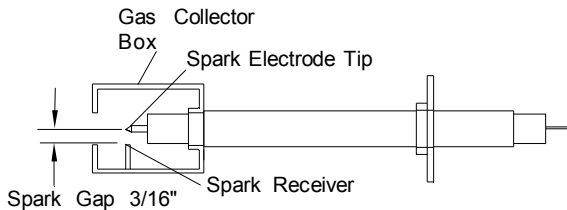

(for Model BTE2614(A,B)LP/NG)

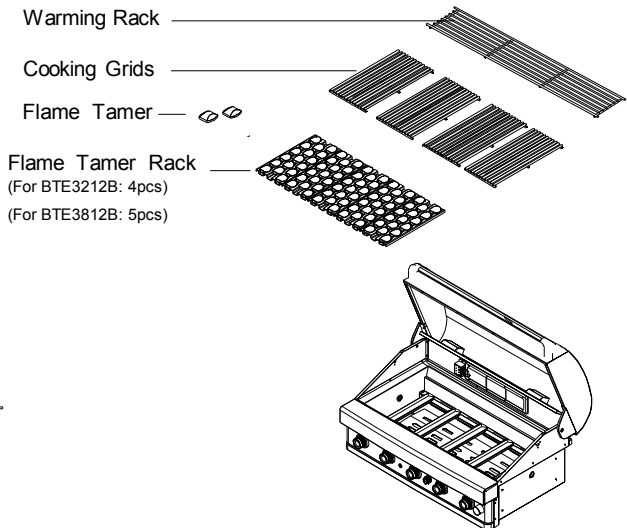

(for Model BTE3212(A,B)LP/NG & BTE3812BLP/NG)

8

Rotisserie Burner Electrode Check

- Push and turn rotisserie burner control knob to . Look for spark between electrode tip and spark receiver tip.
- If you don't see a spark from the rotisserie burner, adjust the gap between the electrode tip and spark receiver tip to 3/16" wide.

9

Install Cooking Components

- Place the flame tamer rack inside the grill bowl. Position it onto the lower ledge of the bowl above the burners. Next, place the flame tamers on the flame tamer rack. (See the diagrams on right)
- Place the cooking grids on the ledge above the flame tamers.
- Place the warming rack into the slots on grill bowl side panels.

Final Grill Assembly Step

When you have finished assembling your grill, be sure that all screws are tightened for safe operation of your grill.

Before each use of the grill, make sure the Grease Tray is fully seated under the Grill Bowl.

CAUTION: Before each use of your grill, inspect the Grease Tray, Grease Tray Heat Shield and inside of the Grill Bowl to be sure there is no excessive grease and debris buildup. Clean the Grease Tray, Grease Tray Heat Shield and inside of the Grill Bowl frequently to eliminate grease/debris build-up and to prevent grease fires.

USE AND CARE INSTRUCTIONS

CORRECT LP GAS TANK USE

- LP Gas grill models are designed for use with a standard 20 lb. Liquid Propane Gas (LP Gas) tank (sold separately). **Never** connect your gas grill to an LP Gas tank that exceeds this capacity. A tank of approximately 12 inches in diameter by 18-1/2 inches high is the maximum size LP Gas tank to use. **You must use an "OPD" gas tank which offers a listed Overfill Prevention Device.** This safety feature prevents tank from being overfilled which can cause a malfunction of the LP Gas tank.
- The LP Gas tank must be constructed and marked in accordance with the Specifications for LP-Gas Cylinders of the U.S. Department of Transportation (D.O.T.) or the National Standard of Canada, CAN/CSA-B339, Cylinders, Spheres and Tubes for Transportation of Dangerous Goods and Commission; as applicable.
- The LP Gas tank must have a shutoff valve, terminating in an LP Gas supply tank valve outlet, that is compatible with a Type 1 tank connection device. The LP Gas tank must also have a safety relief device that has a direct connection with the vapor space of the tank.
- The tank supply system must be arranged for vapor withdrawal.
- The LP Gas tank must have a collar to protect the tank valve.
- Never connect an unregulated LP gas tank to your gas grill. The gas regulator assembly supplied with your gas grill is adjusted to have an outlet pressure of 11" water column (W.C.) for connection to an LP gas tank. Only use the regulator and hose assembly supplied with your gas grill. Replacement hose and regulator assembly must be identical to those listed in the parts list of this Operator's Manual as specified by Grand Hall.
- Have your LP Gas dealer check the relief valve after every filling to ensure it remains free of defects.
- Always keep LP Gas tank in upright position.
- Do not subject the LP Gas tank to excessive heat.
- Never store an LP Gas tank indoors. If you store your gas grill in the garage always disconnect the LP Gas tank first and store it safely outside.
- LP Gas tanks must be stored outdoors in a well-ventilated area and out of the reach of children.
- Disconnected LP Gas tanks must not be stored in a building, garage or any other enclosed area.
- The regulator and hose assembly can be seen by opening the cabinet door and must be inspected before each use of the grill. If the hose is damaged in any way, it must be replaced prior to using the grill again.
- Any attempt to convert the grill from one fuel type to another is extremely hazardous and will void the warranty.
- Never light your gas grill with the lid closed or before checking to ensure the burner tubes are fully seated over the gas valve orifices.
- Never allow children to operate your grill. Do not allow children or pets to play near your grill. Always supervise children and pets if they are in the vicinity of the unit.
- Use of alcohol, prescription or non-prescription drugs can impair your ability to properly assemble and safely operate your grill.

- Keep fire extinguisher readily accessible. In the event of a oil/grease fire, do not attempt to extinguish with water. Use type B extinguisher or smother with dirt, sand or baking soda.
- In the event of rain, turn off the burners and gas supply. Wait for the grill to cool, and then place a cover on it.
- Use your grill on a level, stable surface in an area clear of combustible materials.
- Do not leave grill unattended when in use.
- Do not move the appliance when in use.
- Allow the grill to cool before moving or storing.
- Do not use your grill as a heater.
- Never use your gas grill on a balcony, deck, patio above the ground floor of your home.
- This grill is not intended to be installed in or on recreational vehicles and/or boats.
- The grill is not intended for commercial use.
- Never** use charcoal or lighter fluid in this grill.

WARNING

A. Do not store a spare LP-Gas tank under or near this appliance.
 B. Never fill the tank beyond 80 percent full; and
 C. If the information in "(a)" and "(b)" is not followed exactly, a fire causing death or serious injury may occur.

WARNING

Refer to the this table when designing the island unit for the BTE2614BLP/NG, BTE3212BLP/NG & BTE3812BLP/NG. Side* and Rear* show the minimum amount of distance the unit must be from combustibles (ex. Vinyl or wood siding, fences and overhangs) or sources of ignition (ex. Pilot lights on water heaters and live electrical appliances). Height* shows the minimum height the island unit must be starting from the ground up.

Model	Height	Width	Depth	Side*	Rear*	Height*
BTE2614 BLP/NG	9-3/4"	24-1/2"	19-3/4"	36"	36"	29"
BTE3212 BLP/NG	9-3/4"	30-1/2"	19-3/4"	36"	36"	29"
BTE3812 BLP/NG	9-3/4"	38"	19-3/4"	36"	36"	29"

USE AND CARE INSTRUCTIONS

NOTE about LP Gas Tank Exchange Programs

Many retailers that sell grills offer you the option of replacing your empty LP Gas tank through an exchange service. Use only those reputable exchange companies that inspect, precision fill, test and certify their tanks. Exchange your tank only for an OPD safety feature-equipped tank as described in the LP Gas tank section of this guide.

Always keep new and exchanged LP Gas tanks in an upright position during use, transit or storage.

Leak test new and exchanged LP Gas tanks BEFORE connecting one to your grill.

How to Leak Test your LP Gas Tank

For your safety:

All leak tests must be repeated each time your LP Gas tank is exchanged or refilled.

When checking for gas leaks do not smoke.

Do not use an open flame to check for gas leaks.

Your grill must be leak tested outdoors in a well-ventilated area, away from ignition sources such as gas fired or electrical appliances. During the leak test, keep your grill away from open flames or sparks.

Do not use household cleaning agents. Damage to gas assembly components can result.

- Use a clean paintbrush and a 50/50 mild soap and water solution.
- Brush soapy solution onto LP Gas tank in the areas indicated by the arrows. See diagram.
- If growing bubbles appear do not use or move the LP Gas tank. Call an LP Gas Supplier or your Fire Department.

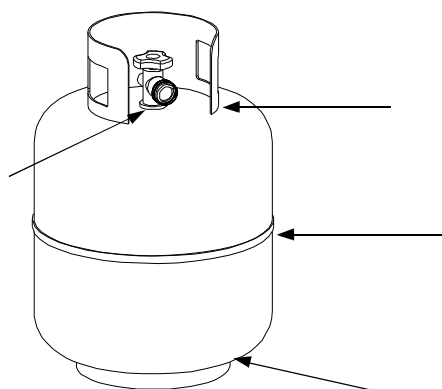

LP Gas Model only:

Secure a 20lb LP Gas Tank to Gas Grill (for BTE26(A,B)LP, BTE3212(A,B)LP & BTE3812BLP)

Note: You can only use a 20lb LP Gas Tank in this Gas Grill.

NOTE: When using Liquid Propane, EXTREME CAUTION should be used to provide ample ventilation of vapor from the enclosure. LP Gas vapor is heavier than air and SERIOUS INJURY from a DANGEROUS EXPLOSION could occur if LP Gas is allowed to accumulate in an enclosure and then ignited. Both the Barbecue enclosure and LP cylinder enclosure require venting that must be provided at the floor level of the enclosure to allow any leaking LP Gas vapor to escape (see Fig. 1).

NOTE: When installing a barbecue equipped for liquid propane(LP) in an island, the propane tank must be in a separate enclosure that is completely isolated from the barbecue. It must be cross-ventilated in accordance with the current standards. The propane tank MUST NEVER be installed directly under the barbecue.

NOTE: The total of the upper ventilation openings must be a minimum of 20 sq. inches. The total of the lower ventilation openings must be a minimum of 10 sq. inches. Upper and lower ventilation openings MUST BE PROVIDED on both sides of built-in construction. The top of the upper ventilation openings must be located within 5" from the top of the island. The bottom of the lower ventilation openings must be at least 1" or less from the floor of the island. The top of the lower ventilation openings cannot be more than 5" from the floor of the island. Every ventilation opening must be a minimum of 1/8". (See Fig. 6 on page 17). Please ask a Grand Hall associate for more details.

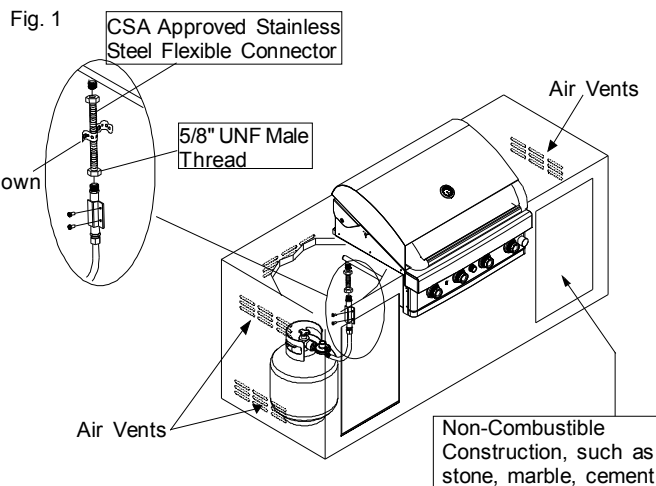

Note:

- The built-in appliance for use with a remote self-contained LP Gas supply system must use rigid pipe, semi-rigid tubing or a connector complying with the Standard for Connections for Gas Appliances, ANSI Z21.24/CSA6.10, or the standard for Connectors Outdoor Gas Appliance and Manufactured Homes, ANSI Z21.75/CSA 6.27 and suitable for outside installation. The maximum length of the connection shall be 6 ft(1.82m).
- The connector should be installed at the location visible when opening the door.
- The connector must be away from any sharp points or sharp edges.
- When using semi-rigid tubing, do not use materials made of aluminium or aluminium alloy.

WARNING

If growing bubbles appear do not use or move the LP Gas tank. Contact an LP Gas Supplier or your fire department!

USE AND CARE INSTRUCTIONS

LP Gas Model only:

Connect Regulator with Hose to your LP Gas Tank

- Turn all Burner Valves to the OFF position.
- Inspect the valve connection port and regulator assembly for damage or debris. Remove any debris. Never use damaged or plugged equipment.
- Connect the regulator assembly to the tank valve and **HAND TIGHTEN** nut clockwise to a full stop. **DO NOT** use a wrench to tighten because it could damage the Quick Coupling Nut and result in a gas leak/fire hazard.
- Open the tank valve 1/4 to 1/2 of a full turn (counterclockwise) and use a soapy water solution to check all connections for leaks before attempting to light your grill. See "Check All Connections for LP Gas Leaks." If a leak is found, turn the tank valve off and do not use your grill until the leak is repaired.

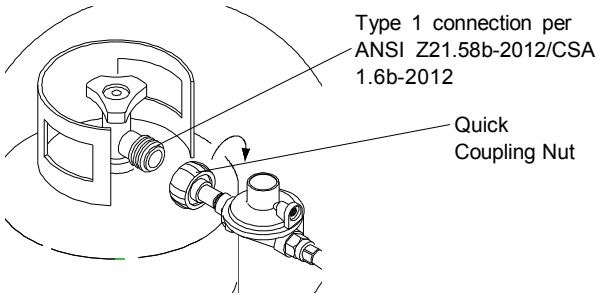

CAUTION: When the appliance is not in use the gas must be turned off at the tank. Place dust cap on cylinder valve outlet whenever the cylinder is not in use. Only install the type of dust cap on the cylinder valve outlet that is provided with the cylinder valve. Other types of caps or plugs may result in leakage of propane.

WARNING

If you have a gas leak that cannot be repaired, turn off the gas at the source and disconnect the fuel line from your grill. Call 1-800-474-5587 or your gas supplier for repair assistance.

WARNING

- 1. Do not store spare LP cylinder within 10 feet (3m) of this appliance.**
- 2. Do not store or use gasoline or other flammable liquids and vapors within 25 feet (8m) of this appliance.**
- 3. When cooking with oil/grease, do not allow the oil/grease to get hotter 350°F (177°C).**
- 4. Do not leave oil/grease unattended.**

Check all connections for LP Gas Leaks

Never test for leaks with an open flame. Prior to first use, at the beginning of each season, or every time your LP Gas tank is changed, you must check for gas leaks. Follow these three steps:

- Make a soap solution by mixing one part liquid detergent and one part water.
- Turn the grill Control Knobs to the full OFF position, then turn the gas ON at source.
- Apply the soap solution to all gas connections indicated by the arrows. See diagram. If bubbles appear in the soap solution the connections are not properly sealed. Check each fitting and tighten or repair as necessary.

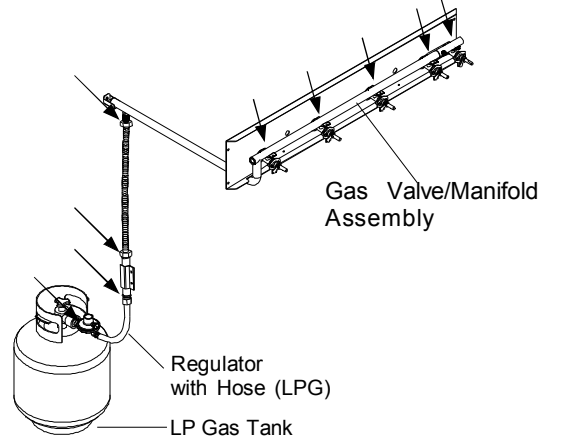
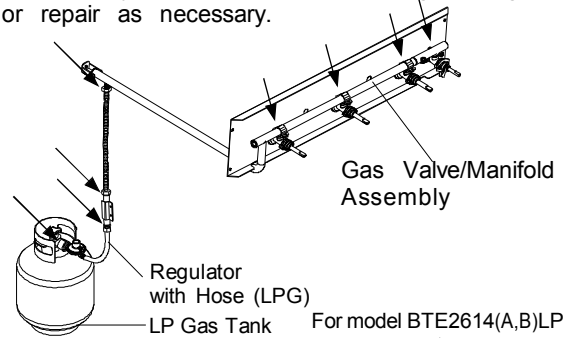

Disconnecting A Liquid Propane Gas (LPG) Tank From Your Grill

- Make sure the Burner Valves and LP Gas tank valve are off. (Turn clockwise to close.)
- Detach the hose and regulator assembly from the LP Gas tank valve by turning the Quick Coupling Nut counterclockwise. Do not use a wrench or any tools when turning the Quick Coupling Nut.

WARNING

Failure to read and follow the Use and Care Instructions could result in a fire or explosion that could cause serious bodily injury, death, or property damage.

Natural Gas Connection

Natural Gas Model only:

Connecting Natural Gas To Your Grill

- Connect the Swivel nut of the 12' Natural Gas Hose to the vertical fitting of NG Regulator as shown in **Fig.1**. Connect the other hose end (male plug) to the gas supply line from your home. Read and follow the "Natural Gas Safety Instructions" below.

Natural Gas Safety Instructions

- Your natural gas grill is designed for use with natural gas (NG) only. The gas pressure Regulator supplied with this appliance **must** be installed and used on your grill. The unit and Regulator are set to operate with an outlet pressure of 4" W.C.
- Install a Shutoff Valve at the gas supply source outdoors at a point after the gas pipe exits the outside wall and before the quick-disconnect hose. Or install it at the point before the gas line piping enters the ground. See **Fig. 2**.
- Pipe sealing compound or pipe thread tape resistant to the action of natural gas must be used on all male pipe thread connections.
- Disconnect your gas grill from fuel source when the gas supply is being tested at high pressures. This gas grill and its individual shutoff valve must be disconnected from the gas supply pipe system during any pressure testing of that system at pressure in excess of 1/2 psi (3.5kpa).
- Turn off your gas grill when the gas supply is being tested at low pressures. The grill must be isolated from the gas supply pipe system by closing its individual manual shutoff valve during any pressure testing of the gas supply pipe system at pressures equal to or less than 1/2 psi (3.5kpa).

Fig.2

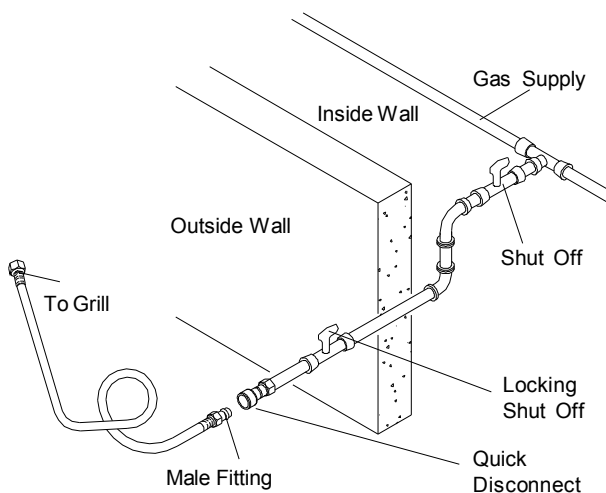
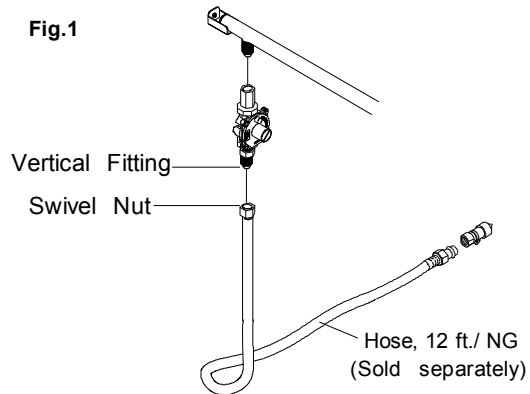

Fig.1



Check all connections for Natural Gas Leaks

Never test for leaks with an open flame. Prior to first use and at the beginning of each season, you must check for gas leaks. Follow these three steps:

- Make a soap solution by mixing one part liquid detergent and one part water.
- Turn the grill Control Knobs to their full OFF positions. Next, turn the gas ON at the source.
- Apply the soap solution to all gas connections indicated by the arrows. See **Fig.3**. If bubbles appear in the soap solution the connections are not properly sealed. Check each fitting and tighten or repair as necessary.

Fig.3

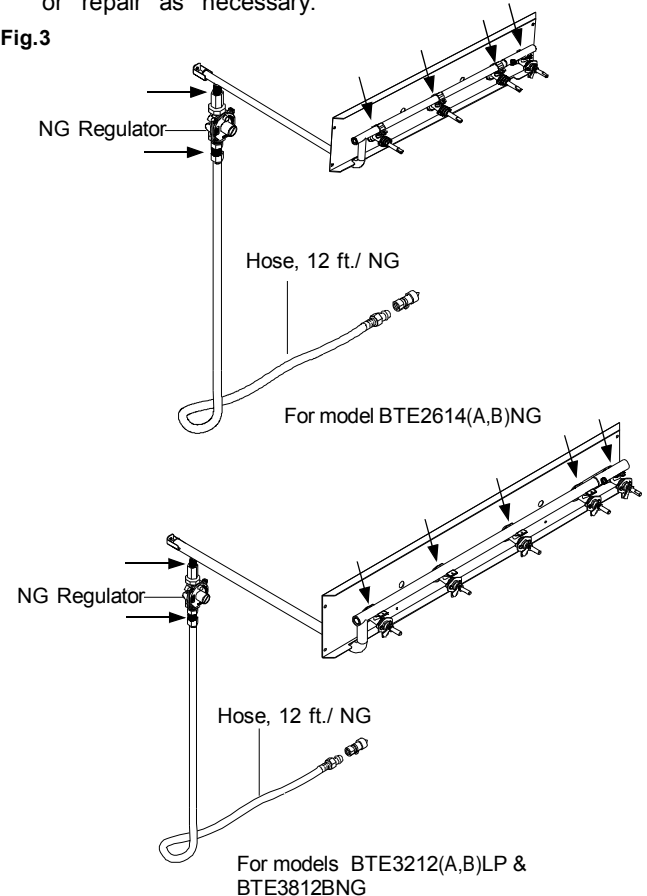

Gas Line Piping:

Please contact certified gas technician for gas line piping installation.

USE AND CARE INSTRUCTIONS

Grill Lighting Instructions

1. Before each use, check all hoses for cracks, nicks, cuts, burns or abrasions. If a hose is damaged in any way, do not use your grill before replacing the hose with an authorized part from the Parts List. Also make sure all gas supply connections are securely tightened.
2. Familiarize yourself with all Safety and Use and Care instructions in this manual. Do not smoke while lighting your grill or when checking the gas supply connections.
3. Be sure the LP Gas tank is filled.
4. Open the Grill Lid.

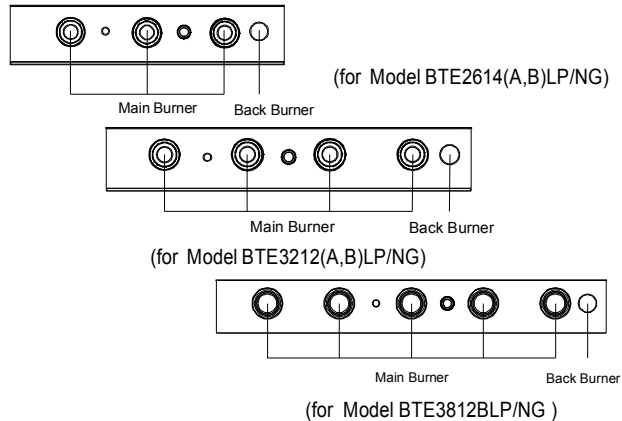

WARNING

Failure to replace a faulty hose, secure gas supply connections or to open the Lid before proceeding to the Lighting Procedures could result in a fire or explosion that could cause serious bodily injury, death, or property damage.

5. Set Control Knobs to OFF and open the LP Gas tank valve **SLOWLY 1/4 of a turn**. For Natural Gas open the Shut Off Valve at source.

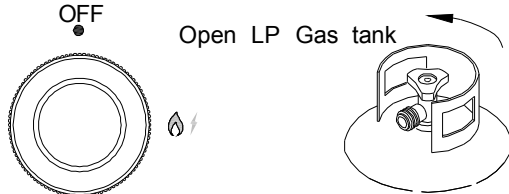

6. Push and turn Right Main Burner Control Knob to . You will hear a clicking sound as the burner is being ignited. Always light the RIGHT Main Burner first.

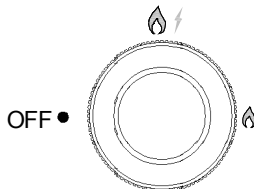

7. If ignition does not occur in 5 seconds, turn the Burner Control(s) off, wait 5 minutes, and repeat the lighting procedure. If ignition still does not occur, turn the burner control(s) and gas source OFF. Wait 5 minutes for gas to clear and then conduct a leak test of ALL gas connections and gas sources as explained in the Use and Care section of this manual. If no leaks are detected, wait 5 minutes for any gas to clear and repeat the lighting procedure.

8. After one Burner is lit, turn the tank valve SLOWLY one more 1/4 of a turn.
9. Turn the adjacent burner knob to . The unlit burner will light automatically. Note: When lighting all main burners, start with the burner furthest from fuel source location, then light remaining burners in sequence moving toward fuel source.

Light Operation

This grill is equipped with two interior halogen lights and decorative knob lights for late night grilling.

1. Push the light switch located on the control panel to turn "ON"/"OFF" interior and knob lights.

WARNING: Do not touch the interior halogen lights. It may be hot and could cause serious burns.

Rotisserie Burner Lighting Instructions

1. Follow steps 1 through 5 of the Grill Lighting Instructions.
2. Push and turn Control Knob to and hold it in 3-5 seconds to ignite the burner. Once the burner is ignited, continue to press and hold it in 5 - 10 seconds before releasing.

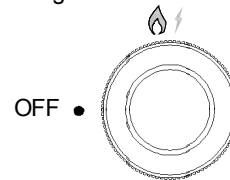

3. If ignition does not occur in 5 seconds, turn the Burner Control off, wait 5 minutes, and repeat the lighting procedure. If ignition still does not occur, turn the burner control and gas source OFF. Wait 5 minutes for gas to clear and then conduct a leak test of ALL gas connections and gas sources as explained in the Use and Care section of this manual. If no leaks are detected, wait 5 minutes for any gas to clear and repeat the lighting procedure.

4. After Burner is lit, turn the tank valve SLOWLY one more 1/4 of a turn.

IMPORTANT: Do not use the Rotisserie Burner and Main Burners at the same time. Rotisserie burner is for Rotisserie Cooking only.

Manually Lighting Your Grill By Paper Match

To light your gas grill by match, insert a match into the Lighting Stick and follow steps 1 through 5 of the Grill Lighting Instructions to light the burners. Then, light the match and place Lighting Stick through the Cooking Grids on the grill (See Diagrams Below) to light the main burners. Turn the correlated Control Knob to the setting to release gas. The Burner should light immediately.

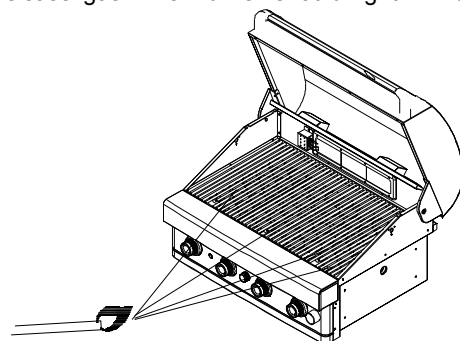

USE AND CARE INSTRUCTIONS



Troubleshooting



If the grill fails to light :



1. Turn gas off at source and turn Control Knobs to OFF. Wait at least 5 minutes for gas to clear, then retry.
2. If your grill still fails to light, check gas supply and connections.
3. Repeat lighting procedure. If your grill still fails to operate, turn the gas off at source, turn the Control Knobs to OFF, then check the following:
 - Misalignment of Burner Tubes over Orifices
Correction: Reposition Burner Tubes over Orifices.
 - Obstruction in gas line
Correction: Remove fuel line from grill. Do not smoke! Open gas supply for one second to clear any obstruction from fuel line. Close off gas supply at source and reconnect fuel line to grill.
 - Plugged Orifice
Correction: Remove Burners from grill by removing the screws from the rear of each Burner using a Phillips Head Screwdriver. Carefully lift each Burner up and away from gas valve Orifice. Remove the Orifices from gas valve and gently clear any obstruction with a fine wire. Then reinstall all Orifices, Burners, screws and cooking components.
 - If an obstruction is suspected in Gas Valves or Manifold, call the Grill Information Center 1-800-474-5587 Monday - Friday 8:00am-4:30pm PST.
 - Obstruction in Burner Tubes
Correction: Follow the Burner Tube cleaning procedure on **page 29** of this Operator's Manual.
 - Misalignment of Ignitor on Burner
Correction: Check for proper position of the Electrode Tip as shown in **steps 7 on page 18**. The gap between the Spark Electrode Tip and Spark Receiver should be approximately 3/16" wide. Adjust if necessary. With the gas supply closed, turn any Main Burner Control Knob to , push in, and watch for the presence of a spark at the end of the Electrode
 - Disconnected Electric Wires
Correction: Inspect the Ignitor Junction Box found behind the Control Panel. Connect loose Electric wires to Junction Box and try to light the grill.
 - Weak AA battery
Correction: Remove the Ignitor Cap and replace the battery.
 - If the grill still does not light you may need to purge air from the gas line or reset the regulator excess gas flow device. **Note:** This procedure should be done every time a new LP Gas tank is connected to your grill.

To purge air from your gas line and/or reset the regulator excess gas flow device:

- Turn Control Knobs to the OFF position.
- Turn off the gas at the tank valve. For Natural Gas close Shut Off Valve.
- Disconnect regulator from LP Gas tank. For Natural Gas disconnect regulator from 12 ft. Natural Gas Hose.
- Let unit stand 5 minutes to allow air to purge.
- Reconnect regulator to the LP Gas tank. For Natural Gas reconnect regulator to 12 ft. Natural Gas Hose.
- Turn tank valve on SLOWLY 1/4 of a turn. For Natural Gas open Shut Off valve.
- Open the Grill Lid.
- Push and turn the Right Main Burner Control Knob to  and you will hear a clicking sound as the burner is being ignited.

	WARNING	
<p>Should a FLASHBACK fire occur in or around the Burner Tubes, follow the instructions below. Failure to comply with these instructions could result in a fire or explosion that could cause serious bodily injury, death, or property damage.</p> <ul style="list-style-type: none"> Y Shut off gas supply to the gas grill. Y Turn the Control Knobs to OFF position. Y Open the Grill Lid. Y Put out any flame with a Class B fire extinguisher. Y Once the grill has cooled down, clean the Burner Tubes and Burners according to the cleaning instructions in this Use and Care Guide. 		

	WARNING	
<p>If ignition does not occur in 5 seconds, turn the Control Knob(s) and gas source OFF and conduct a leak test as explained in the Use and Care section of this guide. If no leaks are detected, wait 5 minutes for any gas to clear and repeat the lighting procedure.</p>		

	WARNING	
<p>Never lean over the grill cooking area while lighting your gas grill. Keep your face and body a safe distance (at least 18 inches) from the front of grill when lighting your grill by match.</p>		

USE AND CARE INSTRUCTIONS

CORRECT ROTISSERIE USE

Read all instructions before initial use.

IMPORTANT: When using electrical appliances, basic safety precautions should always be used.

The Rotisserie Motor is set for 120V, 60Hz AC current.

The Rotisserie is for outdoor use only.

Do not equip your rotisserie with meat in excess of 10-12 pounds.

Do not let children operate or play nearby your grill or Rotisserie. Always supervise children and pets if they are in the vicinity of the unit.

Connecting Rotisserie

Always attach the assembled Rotisserie to your grill first and then plug the Cord into a properly grounded outlet.

Operating Rotisserie

Do not operate the Rotisserie if the cord or plug has been damaged in any manner. Do not use the Rotisserie if it cannot be operated safely.

Do not immerse Electrical Cord, Plug or Motor in water or expose to rain, as this may result in an electrical shock.

Disconnect Rotisserie

Be careful as all surfaces will be hot, both grill and Rotisserie parts. Use protective mitts to handle the Rotisserie. Unplug the Rotisserie from electrical outlet when not in use and before cleaning. Allow to cool before adding or removing parts.

When Rotisserie cooking place a Cooking Pan under the food to be cooked as this will capture the drippings and keep your grill clean of excess grease which could cause a fire.

CAUTION: Handle with care when moving a Cooking Pan with hot oils.

Should a grease fire occur, turn the burners and gas off and leave the grill lid closed until the fire is out.

Store the Rotisserie indoors

When Rotisserie is not in use, store it indoors in a dry place.

CORRECT TRANSFORMER AND LIGHT USE

Read all instructions before initial use.

IMPORTANT: When using electrical appliances, basic safety precautions should always be used.

The Transformer is set for 120V, 60Hz AC current input, 12VAC, 25W output. The Light is set for 12V, 10W.

Do not let children operate or play nearby your grill or Transformer. Always supervise children and pets if they are in the vicinity of the unit.

Connecting Transformer

Always attach the assembled Transformer to your grill first and then plug the Cord into a properly grounded outlet, then turn on the Lights.

Operating Transformer and Light

Do not operate the Transformer if the cord or plug becomes damaged, or if the Transformer or Light malfunctions or have been damaged in any manner.

Do not operate the Transformer if the cord or plug has been damaged in any manner. Do not use the Transformer and Light if it cannot be operated safely.

Do not immerse Electrical Cord or Plug in water or expose to rain, as this may result in an electrical shock.

Disconnect Transformer

Be careful as all surfaces will be hot, including grill, Transformer and the Light. Turn off the Lights and unplug the Transformer from electrical outlet when not in use and before cleaning.



WARNING



To protect against electrical shock, do not immerse electrical cord, plugs or motor in water or expose to rain. Protect electrical elements from burners, hot grill surfaces and grease.



CAUTION



To protect against shock hazard risk, connect only to properly Grounded Outlet.



WARNING



California Proposition 65

The electrical supply cord and plug of the Rotisserie and Transformer contain chemicals, including lead, known to the State of California to cause cancer, and birth defects or other reproductive harm. Wash hands after handling.

ELECTRICAL EQUIPMENT USE

1. To protect against electric shock, do not immerse cord or plugs in water or other liquid.
2. Allow Rotisserie and Grill to cool before putting on or taking off parts.
3. Do not operate any outdoor cooking gas appliance with a damaged cord, plug, or after the appliance malfunctions or has been damaged in any manner.
Call 1-800-474-5587 for repair.
4. Do not let the cord hang over the edge of a table or touch hot surfaces.
5. Do not use an outdoor cooking gas appliance for purposes other than its intended use.
6. When connecting, first connect plug to the outdoor cooking gas appliance then plug appliance into the outlet.
7. Use only a Ground Fault Interrupter (GFI) protected circuit with this outdoor cooking gas appliance.
8. Never remove the grounding plug or use with an adapter of 2 prongs.
9. Use only extension cords with a 3 prong grounding plug, rated for the power of the equipment, and approved for outdoor use with a W-A marking.



WARNING



This appliance, when installed, must be electrically grounded in accordance with local codes or, in the absence of local codes, with the *National Electrical Code*, *ANSI/NFPA 70*, or the *Canadian Electrical Code*, *CSA C22.1*.

Keep any electrical supply cord and the fuel supply hose away from any heated surface.

Rotisserie Instructions

1. Remove all components from the carton.
2. Attach the Motor Bracket on the outside of the right bowl side panel. Align the two holes of the Bracket with the holes on the right bowl side panel. Tighten securely using 2 Rotisserie Screws 3/16"x1/2" UNC, 2 Rotisserie Washers 3/16", and 2 Hex Nuts 3/16" as shown in diagram below.

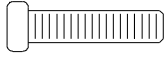

Rotisserie Screw 3/16"x1/2" UNC
Qty. 2
Part # S112G03081

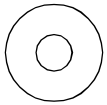

Rotisserie Washer 3/16"
Qty. 2
Part # S411G03081



Hex Nut 3/16"
Qty. 2
Part # S362G10121

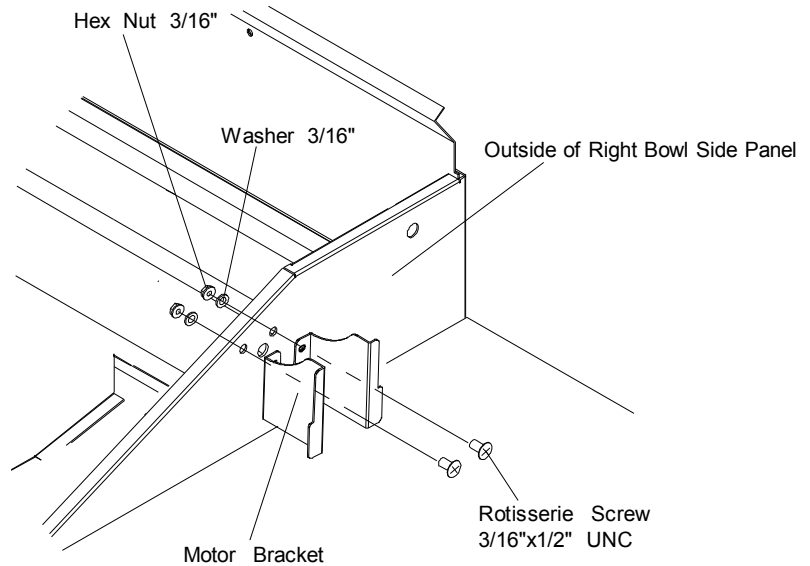

3. Install the AC(alternating current) Rotisserie Motor onto the Motor Bracket as shown below. Be sure the Motor attaches to the Bracket with the electrical cord down. The Motor should be on the right side of your grill.

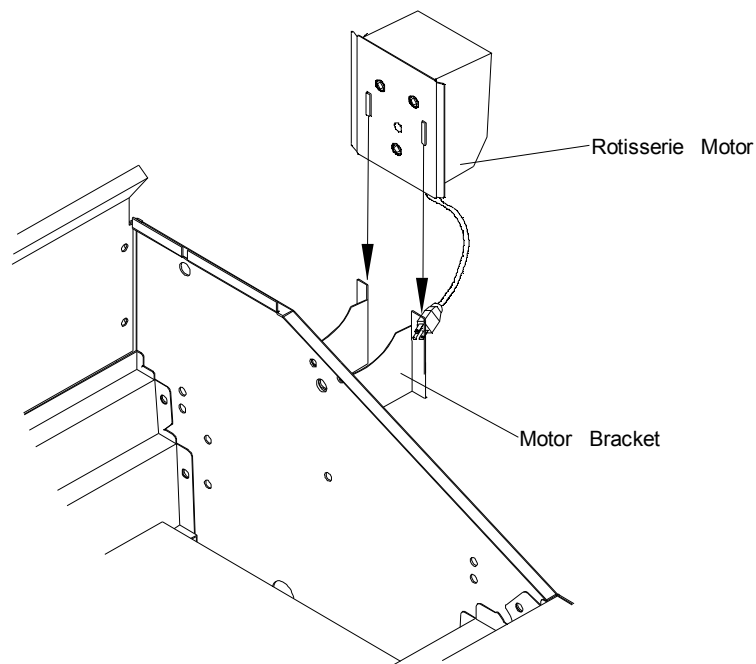

- Slide the pointed end of the Spit through the piece of meat. Place the Holding Forks onto each end of the Spit. Adjust spacing between Holding Forks to accommodate your food, then tighten the Thumbscrews to keep the Holding Forks in position. Slide the Collar onto the square end of the Spit. Do not tighten the Collar Thumbscrew until the Rotisserie is placed into your grill.

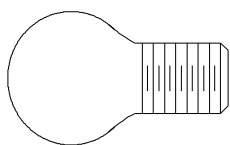

Rotisserie Thumbscrew 1/4"x1/2"
Qty. 3
Part # S196G04084

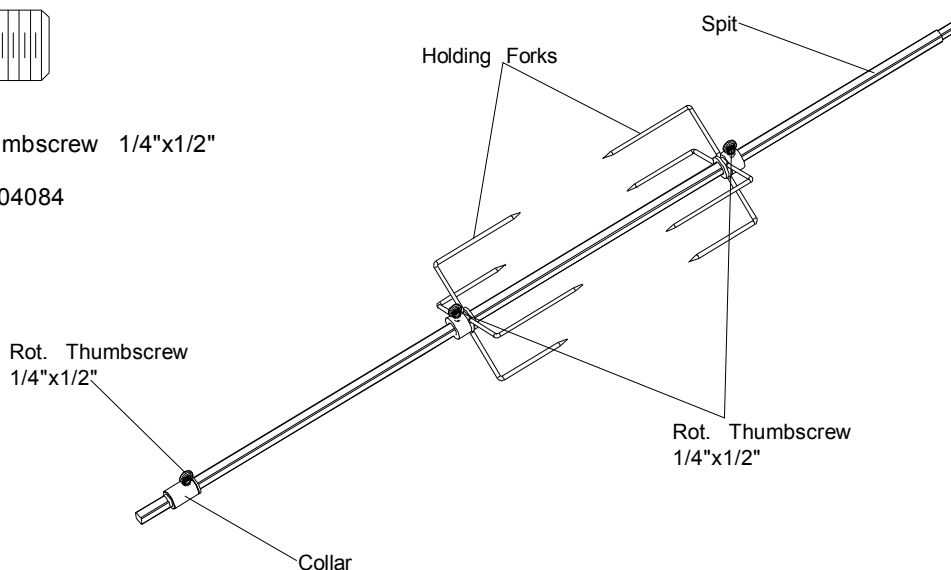

- Insert the square end of assembled rotisserie Spit into the round hole on the left side panel. Next insert the pointed end of the Spit into the Motor as shown below. Place the Collar into the round hole on the left side of your grill bowl, then tighten the Collar Thumbscrew. The Collar will stabilize the Rotisserie during the cooking process and allows the Rotisserie Spit to turn smoothly. Plug the Rotisserie Motor cord into an outlet and turn on to test.

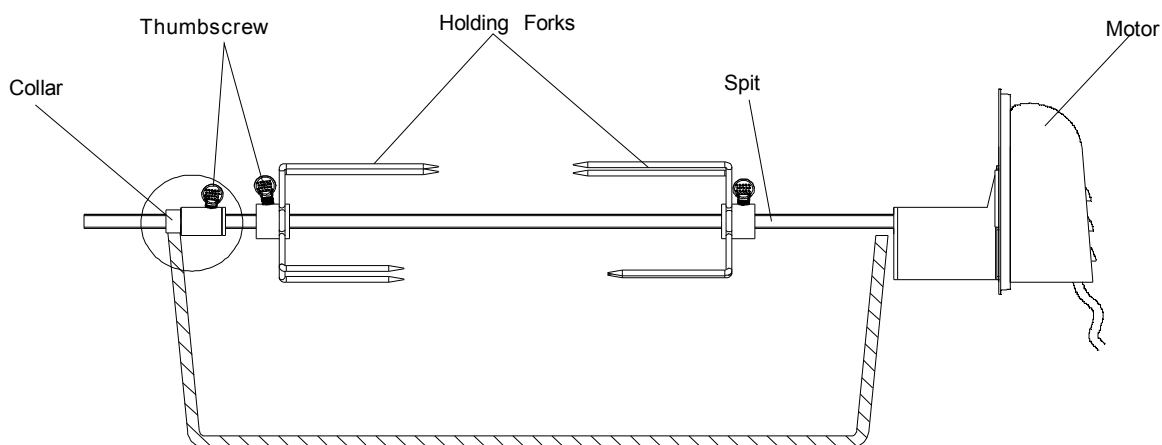

The Collar must always be used with this Rotisserie

BEFORE rotisserie cooking you will need to remove the Warming Rack, Cooking Grid(s) and possibly the Flame Tamer/Rack from your grill. When rotisserie cooking place a Cooking Pan under the food to be cooked. This will capture the drippings and keep your grill clean of excess grease which could cause a fire. Use caution when moving a Cooking Pan containing hot oils.

CLEANING AND MAINTENANCE

Proper care and maintenance will keep your grill in top operating condition and prolong its life. Follow these cleaning procedures on a timely basis and your grill will stay clean and operate with minimum effort.

CAUTION: Be sure your grill is OFF and cool before cleaning.

Cleaning the Cooking Grids

- Before initial use, and periodically thereafter, wash your Cooking Grids in a mild soap and warm water solution. You can use a wash cloth or vegetable brush to clean your Cooking Grids.

Cleaning the Flame Tamer Rack

- You should periodically wash the Flame Tamer Rack in a soap and warm water solution. Use a vegetable brush to remove stubborn burnt-on cooking residue. Dry the Flame Tamer Rack thoroughly before you reinstall them into the cooking bowl.

Cleaning the Grease Tray

- To reduce the chance of fire, the Grease Tray should be visually inspected before each grill use. Remove any grease and wash Grease Tray with a mild soap and warm water solution.

Cleaning the Inside of the Grill Lid

- Grease can build up on the inside of the Grill lid over time. This grease can drip onto your deck or patio when the lid is opened. Visually inspect the inside of the Grill Lid before each grill use. Remove any grease and wash with a mild soap and warm water solution.

Routine Cleaning of The Grill Interior

- Burning-off excess food after every cookout will keep it ready for instant use. However, at least every 3 months you must give the entire grill a thorough cleaning to minimize your risk of grease fire and keep the grill in top shape. Follow these steps:
 1. Turn all Control Knobs to the full OFF position.
 2. Turn the LP gas tank valve to the full OFF position.
 3. Disconnect the regulator from the gas tank. Inspect the hose with regulator assembly for cracking, cuts or any other damage, and replace as necessary. Refer to the Parts List in this Use and Care Guide.
 4. Remove and clean the Flame Tamer Rack, Cooking Grids, Warming Rack and Grill Burners.
 5. Cover each Gas Valve Orifice with aluminum foil.
 6. Brush the inside and bottom of the grill with a fiber pad or nylon brush and wash with a mild soap and warm water solution. Rinse thoroughly and let dry.
 7. Remove aluminum foil from Orifices and check each Orifice for obstruction.
 8. Check each Spark Electrode, adjusting as needed. The space between the Spark Electrode Tip and Spark Receiver should be approximately 3/16".
 9. Replace the Burners and adjust the Gas Collector Box. The edge of the collector box should be overlapping the Burner Port.
 10. Replace Flame Tamer Rack and Cooking Grids.
 11. Reconnect the gas source and observe the Burner flame for correct operation.



WARNING



Do not leave the grill unattended during burn off. Empty and clean the grease tray before doing burn-off.

Cleaning Exterior Stainless Steel Surfaces:

- Routine care and maintenance is required to preserve the appearance and corrosion resistance of stainless steel. The fact is stainless steel can corrode, rust and discolor under certain conditions. Rust is caused when regular steel particles in the atmosphere become attached to the stainless steel surface. Steel particles can also become attached to your grill if you use steel wool or stiff wire brushes to clean the grill instead of non-abrasive cloth, sponge or nylon cleaning tools. In coastal areas rust pits can develop on stainless surfaces that cannot be fully removed. Bleach and other chlorine based solutions used for household and pool cleaning can also cause corrosion to stainless steel. Weathering, extreme heat, smoke from cooking and machine oils used in the manufacturing process of stainless steel can cause stainless steel to turn tan in color. Although there are many factors which can affect the surface appearance of stainless steel, they do not affect the integrity of the steel or the performance of the grill.

- To help maintain the finish of stainless steel follow these cleaning procedures for the best results:
 1. After every use (after your grill has cooled down), wipe stainless surfaces with a soft, soapy cloth or sponge then rinse with water. Be sure to remove all food particles, sauces or marinades from stainless steel because these can be highly acidic and damaging to stainless surfaces.
 2. Never use abrasive cleaners, scrubbers or stiff wire brushes of any type on your grill.
 3. Use a heat resistant Stainless Steel Cleaner and rub or wipe in the direction of the stainless steel grain or polish lines. Do not polish against the grain.



WARNING



Failure to comply with these instructions could result in a fire or explosion that could cause serious bodily injury, death or property damage.

- Keep grill area clear and free from combustible materials, gasoline and other flammable vapors and liquids.
- Do not obstruct the flow of air for combustion and ventilation.
- Keep the ventilation openings of the tank enclosure cabinet free and clear of debris.
- Visually check burner flames occasionally to ensure proper flame pattern as shown below.

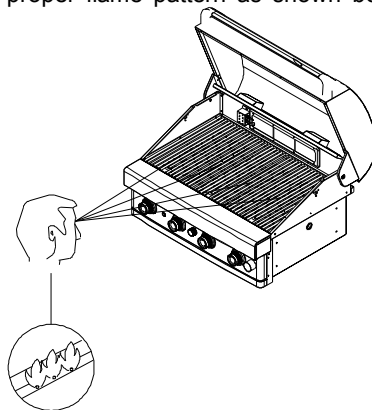

MAGNIFIED VIEW OF GRILL MAIN BURNER AND ROTISSERIE BURNER FLAME THROUGH OPEN LID.

CLEANING THE BURNER TUBES AND BURNER PORTS

To reduce the chance of **FLASHBACK FIRE** you must clean the Burner Tubes as follows at least once a month in summer and fall or whenever spiders are active in your area, and if your grill has not been used for an extended period of time.

1. Turn all Burner Valves to the full OFF position.
2. Turn the LP Gas tank valve to the full OFF position. For Natural Gas, shut off Natural Gas Valve.
3. Detach the LP Gas regulator assembly from your gas grill.
4. Remove the Warming Rack, Cooking Grids and Flame Tamer Rack with Tamers from your grill.
5. Remove the screws from the rear of each Main Burner using a Phillips Head Screwdriver.
6. Carefully lift each Burner up and away from the Gas Valve Orifice.
7. Check and clean burner/venturi tubes for insects and insect nests. A clogged tube can lead to a fire beneath the grill.
8. Refer to **Figure 1** and perform one of these three cleaning methods:

- METHOD 1:** Bend a stiff wire or wire coat hanger into a small hook as shown and run the hook through the Burner Tube and inside the Burner several times to remove debris.



- METHOD 2:** Use a bottle brush with a flexible handle and run the brush through the Burner Tube and inside the Burner several times to remove any debris.
- METHOD 3:** Use an air hose to force air through each Burner Tube. The forced air should pass debris or obstructions through the Burner and out the Ports.

Regardless of which Burner cleaning procedure you use, we recommend that you also complete the following cleaning regimens to help prolong Burner life.

- After each use of the main grill, it is necessary to burn off food particles and drippings which can clog Burner ports and reduce Burner performance. OPEN the grill Lid, ignite the burner(s) and operate grill on setting for 10 to 15 minutes. You can close the Lid if only main Burners are lit.
- Use a nylon brush, blower or vacuum to remove accumulated ash from the outer surface of each Burner. Clogged tube style Burner ports can be cleaned with a stiff wire, such as an open paper clip.
- Inspect each Burner for damage (cracks or holes) and if such damage is found, order and install a new Burner. After installation, check to ensure that the Gas Valve Orifices are correctly placed inside the ends of the Burner Tubes. Also check the position of your Spark Electrode.

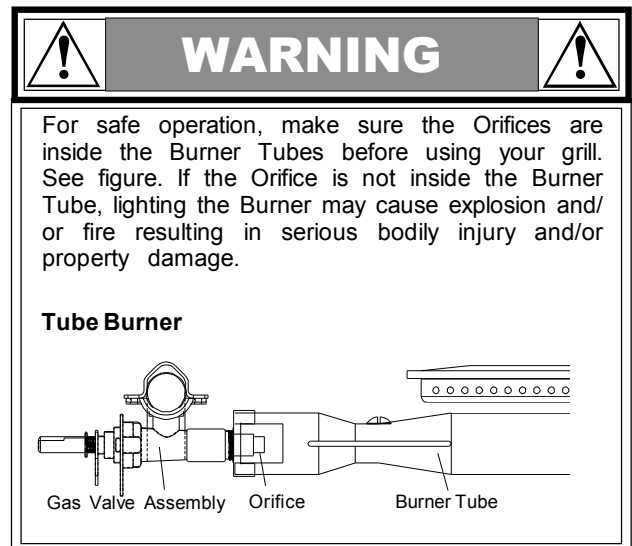
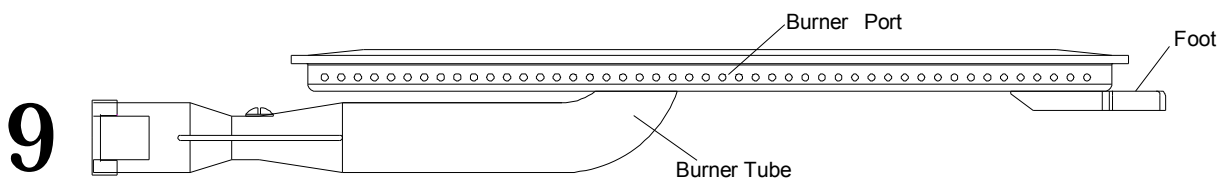



Figure 1

TO CLEAN BURNER TUBE, INSERT HOOK AS INDICATED BY THE ARROW



Cooking Instructions

Burn-Off

- Before cooking on your gas grill for the first time, you should "burn off" the grill to eliminate any odor or foreign matter. Ignite the main burners, lower the Lid, and operate grill on  setting for 10 to 15 minutes.



CAUTION: Operating your grill on the  setting for longer than 15 minutes may damage certain parts of your grill. **Do not leave your grill unattended when in use.**

Preheating

CAUTION: Before preheating the grill, check the Grease Tray, Grease Tray Heat Shield and inside of the Grill Bowl to be sure there is no excessive grease and debris buildup. As needed, you may clean them. Refer to "Cleaning Instructions" on page 30. **Failure to comply with these instructions could result in a grease fire.**

- To preheat your grill, light all main burners on , lower the Lid and follow the recommended times below.
- ✓ For high temperature cooking, preheat grill 10 to 15 minutes.
- ✓ For low temperature cooking, preheat grill 3 minutes.
- ✓ To slow cook, preheating is not necessary.

Cooking Temperatures

- **High setting:** The  Control knob setting should be used to pre-heat your grill and for burning food residue off. Besides, please refer to the Direct Cooking Method of this manual.
- **Low Setting:** Most recipes specify the  settings, including all smoking and cooking lean cuts such as fish.

An Important Note About Cooking Temperatures

- The suggested heat settings and cooking times shown in the following pages are approximate. Unlike the controlled environment inside your kitchen, variables including outside temperatures, direction and conditions of wind, as well as grill location will affect your grill's heat distribution. Because these conditions vary, and no two backyards are alike, we offer these tips as general guidelines for your reference. We recommend you monitor your grill closely and rotate foods as needed to prevent overcooking and ensure the most delicious results every time.
- ✓ The middle and back primary cooking areas offer high heat for grilling.
- ✓ The Warming Rack offers medium heat for preparing breads and firm vegetables.
- ✓ The front primary cooking area offers less heat and is ideal for preparing delicate foods and for keeping cooked foods warm.

Direct Cooking using Main Burners

- The direct cooking method can be used with the supplied Cooking Grids and food placed directly over the lit grill Burners. **Direct Cooking requires the Grill Lid to be open.** This method is ideal for searing and grilling when you want an open-flame barbecued taste.

Indirect Cooking using Main Burners

- The indirect cooking method can also be used with the supplied Cooking Grids. To cook **indirectly**, the food should be placed on the left or right side of your grill with the main Burner lit on the opposite side. Or place your food on the Warming Rack and light the outer main Burners. Either way, **indirect cooking must be done with the Lid down.**

Prepare Cooking Grids for Grilling

- Greasing the cooking surface will help keep foods from sticking during the cookout and reduces the amount of cleanup required. Use a brush to apply a thin layer of cooking oil or vegetable shortening onto each Cooking Grid before each cookout. We do not suggest spray type oils unless they are specified for high-temperature cooking. Be sure to coat the entire cooking surface.

Flare-Ups

- The fats and juices dripping from grilled food can cause flare-ups which impart a favorably, distinctive taste and color to food. They should be accepted up to a point. To minimize flare-ups:
 - ✓ Trim excess fat from meats and poultry
 - ✓ Preheat the grill properly
 - ✓ Clean grill regularly to remove food and grease build-up
 - ✓ Reposition your food often to avoid flare-ups



WARNING



- ✓ Failure to comply with these instructions could result in a fire or explosion that could cause serious bodily injury, death or property damage.
- ✓ **Never** cover or wrap the cooking grids, Flame Tamers, bottom of grill bowl or Grease Tray with charcoal, aluminum foil, sand or any substance that can absorb grease.
- ✓ **Before each use of your grill:** Inspect the Grease Tray, Grease Tray Heat Shield and inside of the Grill Bowl to be sure there is no excessive grease and debris buildup. Clean the Grease Tray, Grease Tray Heat Shield and inside of the Grill Bowl frequently to eliminate grease/debris build-up and to prevent grease fires.
- ✓ **Use your grill at least 3 feet away from any wall or surface.** Use your grill at least 3 feet away from combustible objects that can melt or catch fire (such as vinyl, wood siding, fences and overhangs) or sources of ignition (including pilot lights on water heaters and live electrical appliances).
- ✓ **Never** use your gas grill in a garage, porch, shed, breezeway or any other enclosed area.
- ✓ **Never** use your gas grill on a balcony, deck, patio above the ground floor of your home.
- ✓ **Your grill will get very hot.** Always wear a flame retardant BBQ Mitt when cooking on your grill. Never lean over cooking areas while using grill. Do not touch cooking surfaces, Lid, grill housing or other parts while grill is in operation, or until the grill has cooled down after use.

Guide to Grilling using the Main Burners and Direct Cooking Method

Grilling Steak and Ribs

Turn the grill Burners on , close Lid and preheat your grill 10 to 15 minutes. Open Lid and place the meat on the Cooking Grid directly above the lit Burners. Cook the meat on both sides until seared. Reduce the heat to LOW and cook meat until done. Grilling times will vary according to meat thickness.

Grilling Hamburgers and Sausages

Turn the grill Burners on , close Lid and preheat your grill 10 to 15 minutes. Open Lid and place the meat on the Cooking Grid directly above the lit Burners. Cook the meat on both sides until seared. Reduce the heat to LOW and cook the meat until done. Grilling times will vary according to meat thickness.

Grilling Poultry

Turn the grill Burners on , close Lid and preheat your grill 10 to 15 minutes. Then raise the Lid, reduce heat to LOW and cook poultry directly over lit Burners until done. Poultry skin is fatty so you should expect some flare-ups when using this direct method.

To minimize flare-ups, try grilling poultry using the indirect method. Place the poultry on one side of the grill with the opposing Burners on LOW heat, and lower the grill Lid. Grilling times will vary based on the size of your poultry.

Grilling Pork

Turn Burners on and preheat your grill 10 to 15 minutes with the Lid closed. Raise Lid, place pork on Cooking Grid and cook until seared. Reduce heat to LOW and cook until done. Grilling times will vary according to meat thickness.

Whole Fish and Whole Fillets

Preheat your grill on for 10-15 minutes with the Lid down. Raise lid and turn Burners to LOW heat. Place fish (skin down) on grill and cook over direct heat until done. Use cooking time as a guide or until fish is opaque but still moist.

Smaller Fish Fillets and Cubes

Follow the directions from above, using approximate cooking times shown at right. Place a small piece of aluminum foil on the Cooking Grids if the fish pieces are small enough to drop between the Cooking Grids.

Vegetables and Fruit

Prepare your fruit or vegetables and brush with butter or basting sauce if desired. To cook **indirectly**, the food should be placed on the left or right side of your grill with the Burner lit on the opposite side and the grill lid down. Or center your food on the Warming Rack and light the outer grill Burners. Either way, **indirect cooking must be done with the Lid down.**

In some instances, you may want to grill vegetables and fruit **directly** over the heat, using the supplied Cooking Grids. Foods that work best with direct heat are relatively soft and require a short cooking time: mushrooms, zucchini, tomatoes and skewered fruit such as apricots, peaches, pineapple, strawberries and kiwis. Remember the **Grill Lid must remain up when cooking directly.**

Cut of Meat

T-bone steak
Sirloin steak
Beef spare ribs
Porterhouse steak
New York strip steak

Hamburgers
Sausages

Chicken breast
(cook with bone down)
Chicken wings
Drumsticks

Whole bird
(cook with breast up)

Chops
Loins
Cutlets

Whole fish
Whole fish fillets

Fish fillets
Boneless cubes

Approximate Cooking Times

Rare: 4-8 minutes
Medium: 10-14 minutes
Well done: 15-20 minutes

Rare: 4-6 minutes
Medium: 8-10 minutes
Well done: 10-15 minutes

Direct method:
approximately 15 minutes
Indirect method:
up to 30 minutes

Indirect method:
approximately 1 hour

Medium: 10-14 minutes
Well done: 15-20 minutes

10-12 minutes per pound or
until fish is opaque

4-5 minutes each side
or until fish is opaque

For very firm vegetables, particularly potatoes and yams, we recommend that you partially boil until almost cooked, before placing them on the grill. Cooking times using the **indirect method** with the lid down will be similar to those for your kitchen oven. However, there are many factors such as outside temperature, wind conditions and location of grill that affect your grill performance so we suggest you watch the temperature gauge and adjust the heat accordingly.

Cooking times for foods prepared with the **direct method** will be much shorter because of the direct heat source. Timing will be comparable to normal pan frying or grilling.

Guide to Roasting and Baking Using the Main Burners

An Important Note About Heat Settings

The suggested heat settings shown are approximate. There are many factors such as outside temperature, wind conditions and grill location that affect your grill performance. We offer these cooking times as general guidelines, but suggest you watch the temperature gauge and adjust the heat accordingly.

Preparing to Roast

Roasting uses the **indirect cooking** method. Therefore, the food should be placed on the left or right side of your grill with the Burner lit on the opposite side. You can also use the supplied Cooking Grid with an aluminum drip pan underneath allowing you to collect juices for making gravies. Remember, indirect cooking requires the Lid of your grill to be down.

Preheating your grill is not required for slow cooking methods such as roasting. If you do choose to preheat your grill before roasting, turn the Burners on  and close Lid for approximately 2-3 minutes.

Food preparation

Trim meat of excess fat. Truss meat and poultry with cooking string to retain shape if desired. Bacon strips can be used to cover the outside surface of lean meat and poultry to help prevent it from drying out. Another method for keeping food moist during roasting is to put water in a cooking pan, then cover with foil. The foil should be removed for the first or the last part of the cooking time to ensure proper browning.

Tips for roasting

Except when roasting with water in a roasting pan, the juices that collect in the pan can be used as the base for a tasty sauce or gravy. Place a cooking pan directly over the heat, add extra butter if needed, then add several spoonfuls of flour to thicken sauce. Finally, add sufficient chicken or beef stock to obtain the desired consistency.

Once the meat is cooked, remove it from your grill and cover with a piece of foil. Allow it to stand for 10-15 minutes which allows the juices to settle. This will make carving easier and ensure a tender, juicy roast.

Type of Food	How Cooked	Approximate Cooking Times
Beef	Rare	18 minutes per pound
	Medium	23 minutes per pound
	Well done	27 minutes per pound
Lamb	Medium	18 minutes per pound
	Well done	23 minutes per pound
Veal		27 minutes per pound
Pork		30-33 minutes per pound
Chicken		20-25 minutes per pound
Duck		25 minutes per pound
Fish		10 minutes per pound
Turkey, under 16 pounds		20-25 per pound + 30 minutes
Turkey, over 16 pounds		18-23 per pound + 15 minutes

BAKING TECHNIQUES

From casseroles and cornbread to delicious desserts like fondue fruit skewers or crumble cake, baking on the grill is as easy as baking in the kitchen.

Preparing to Bake

To bake in your new grill you'll need a baking dish or cast-iron cooking pan, and a pair of flame retardant BBQ Mitts. If the cooking pan is cast-iron be sure to season the pan before use.

Preheat your grill 3-5 minutes, then lower heat to achieve the baking temperature desired. Baking uses the **indirect cooking** method. Therefore, your cooking pan should be placed on the left or right side of your grill with the burner lit on the opposite side.

Oven Temperature

Slow	300° - 340° F
Moderate	355° - 390° F
High	410° - 480° F

Tips for Baking

Prepare your favorite recipe as you would in the kitchen. Foods cooked in the grill for long periods of time should always be covered in aluminum foil to retain moisture. You will need to stir the food several times as it bakes, and add additional liquid if required.

Watch the temperature, and adjust to cook according to your recipe directions.

Recommended Grill Setting

Both outside Burners on LOW
1 outside Burner on Hi and 1 outside Burner on LOW
Both outside Burners on Hi

Guide to Rotisserie Cooking

Slow Cooking with a Rotisserie

Rotisserie cooking produces foods that are moist, flavorful and attractive. The rotisserie system is most commonly used for cooking meat or poultry and is designed to cook food slowly.

The cooking times on a rotisserie will be approximately the same as for oven cooking.

Balancing the Food

In rotisserie cooking, balancing the food is of utmost importance. The rotisserie must turn evenly or the stopping and starting action will cause the food to cook unevenly and possibly burn the heavier side.

The easiest foods to balance are those of uniform shape and texture. To test if the food is balanced correctly when secured, place the ends of the rotisserie spit loosely in the palms of your hands. If there is no tendency to roll, give the spit a quarter turn. If it is still stable, give it a final quarter turn. It should rest without turning in each of these positions. It can then be attached to your grill.

Food Preparation

When preparing poultry, truss the birds tightly so that wings and drumsticks are close to the body of the bird. The cavity of the bird may be stuffed prior to this. Pull the neck skin down and, using a small skewer, fix it to the back of the bird. Push the rotisserie spit through lengthwise, catching the bird in the fork of the wishbone. Center the bird and tighten with the holding forks. Test the balance as described before.

A rolled piece of meat requires the rotisserie skewer to be inserted through the center of the length of meat, then secured and balanced.

For meats that contain bones, it is best to secure the rotisserie skewer diagonally through the meaty sections. If protruding bones or wings brown too quickly, cover with pieces of foil.

Guide to Smoking

Preparing to Smoke

Smoking gives food a distinctive, delicious flavor. You will find a variety of wood chips available for use in smoking grilled foods. Pre-soaking of wood chips may be required so read and follow the manufacturer's instructions for preparing smoking chips prior to use.

Note: It is our experience that many smoking chip products do not actually produce a smoke but instead infuses the food with flavor. Please read product labels carefully and if in doubt, ask your retailer for details.

Using A Smoker Box

There are many optional smoker boxes available for purchase. Follow these guidelines and always refer to the label of your smoking chips for specific directions.

Raise your Grill Lid and light the grill. Lower the Grill Lid allowing your grill to reach the desired cooking temperature for the food you are grilling. Fill your smoker box with your prepared smoking chips. Dried herbs and spices may also be added to produce different flavors. Wear a flame retardant BBQ Mitt and place your smoker box on a Cooking Grid or Flame Tamer directly above a lit grill Burner. The heated smoking chips will flavor your foods.

Tips for Smoking

You can reduce the strength of the smoke flavor by only smoking for half or three quarters of the cooking time. The heat required for smoking is normally LOW to MEDIUM.

Foods naturally high in oils lend themselves well to smoking, while drier foods benefit from a marinade.

- **Tuna steaks**, marinated in Asian flavors of sesame oil, soy sauce and sherry.
- **Pork filets**, rubbed with ginger, orange rind and brushed with maple syrup.
- **Mussels**, brushed with lemon rind and chili oil.
- **Lamb cutlets**, marinated in virgin olive oil, lemon, oregano and black pepper. The same marinade can be used for a whole leg or rack of lamb.
- **Chicken**, boneless chicken pieces—especially sliced breasts.
- **Fish**, sliced filets of firm fish, assorted seafood such as prawns, scallops and calamari.
- **Pork**, sliced filets, diced or minced pork, sliced leg steak, sliced chops.
- **Beef**, sliced fillet, rib-eye, round, rump, sirloin.
- **Lamb**, sliced fillet, round, loin.

Guide to Using the Warming Rack

Vegetables are generally easy to cook on the grill. The Warming Rack makes it convenient because you can still use the main cooking area while the vegetables are suspended above the grids.

Pre-cook hard vegetables by briefly boiling or microwaving them before cooking on the grill. Wrap vegetables in a double thickness of foil to protect them while cooking on the grill. Then, remove the foil if desired, 10-15 minutes before the end of cooking, brush vegetables with butter or oil and finish cooking.

The Warming Rack can be used for purposes other than just the obvious. Consider using the rack for warming French bread, garlic bread, croissants or even bagels.

A small whole fish wrapped in foil also cooks well on the Warming Rack. Parcels of seafood such as scallops, prawns and sliced fish filets prepared in a sauce and portioned into small foil wraps cook well this way, too.

Question:

Can I convert my grill from one fuel type to another in other words from LPG to NG or vice versa?

Answer:

No, your gas grill is manufactured to exact specifications and is certified for Liquid Propane Gas (LPG) or Natural Gas(NG) use only. For your safety, conversion kits are not available, nor will we sell or otherwise provide parts or information to be used to convert your grill. Any attempt to convert your grill is dangerous and will void your warranty.

Question:

Are the serial and model numbers of my grill listed somewhere for reference?

Answer:

The serial and model numbers are listed on a silver CSA label placed on the grill. This label is located on the Bowl Rear Panel.

Question:

My grill will not light properly. Why?

Answer:

Always light the Main Burner farthest from the fuel source first. This will draw gas across the manifold helping prevent air pockets which obstruct gas-flow and prevent proper grill lighting. Also try this procedure:

1. Turn gas off at source and turn Control Knobs OFF. Wait at least 5 minutes for gas to clear, then retry.
2. If your grill still fails to light, turn the Burner Control Knob(s) and gas source OFF and conduct a leak test of ALL gas connections and gas sources as explained in the Use and Care section of this manual.
3. If no leaks are detected, wait 5 minutes for any gas to clear and repeat the lighting procedure.

Question:

If my ignitor or battery is not working how can I light my grill manually? And - Why would I need the lighting stick that hangs from the side of my grill?

Answer:

If your ignition fails to work or your battery needs replacing, you can light your grill using the Manual Lighting Stick. The Lighting Stick is designed to hold a paper match and allows you to safely insert a match through the Cooking Grid without getting close to the Burner. To light your gas grill manually, insert a paper match into the Manual Lighting Stick and follow steps 1 through 5 of the Basic Lighting Procedures. Then, light the match and place the Lighting Stick through the Cooking Grid. Turn the correlated main Burner Control Knob to the  setting to release gas. The Burner should light immediately.



WARNING

Never lean over the grill cooking area while lighting your gas grill. Keep your face and body a safe distance (at least 18 inches) from the front of grill when lighting your grill by match.

Question:

Sometimes I hear a humming sound coming from my regulator. What causes this? And - My grill has a low flame and sometimes will not light. Why?

Answer:

The humming sound is gas flowing through the regulator. A low volume of sound is normal and will not interfere with the operation of your grill. Loud or excessive regulator humming and/or low flow and intermittent lighting may be caused by the regulator's excess gas flow device. Opening the tank valve all the way or too quickly is what triggers the regulator's safety device to restrict gas flow, preventing excess gas flow to your grill. Lighting the main Burner farthest from the fuel source every time will help eliminate air pockets in the manifold. Note: This procedure should be done every time a new LP Gas tank is connected to your grill.

- Turn all Control Knobs to the OFF position.
- Turn off the LP Gas tank at the tank valve. For Natural Gas close Shut Off NG Valve.
- Disconnect regulator from LP Gas tank. For Natural Gas disconnect regulator from 12 ft. Natural Gas Hose.
- Let unit stand for 5 minutes.
- Reconnect regulator to the LP Gas tank. For Natural Gas reconnect regulator to 12 ft. Natural Gas Hose.
- Open grill Lid.
- Turn the tank valve slowly ¼ of one turn. For Natural Gas open Shut Off valve.
- Light main Burner farthest from fuel source.
- Turn the tank valve slowly one more ¼ of one turn for ½ of one complete turn.
- Continue to light Burners moving towards the fuel source.
- Do not turn tank valve more than ½ of one turn on LPG models.

Question:

Where do I use my grill for safer operation and better performance?

Answer:

- Strong winds and low temperatures can affect the heating and performance of your gas grill so factor in these elements when positioning your grill outdoors for cooking.
- In **windy conditions**, always position the front of grill to face oncoming wind to reduce smoke and heat blowing in your face and prevent potential hazards to yourself and grill.
- Use your grill at least 3 feet away from any wall or surface.
- Use your grill at least 3 feet away from combustible objects that can melt or catch fire (such as vinyl, wood siding, fences and overhangs) or sources of ignition (including pilot lights on water heaters and live electrical appliances).
- Never** use your gas grill in a garage, porch, shed, breezeway or any other enclosed area.
- Never** use your gas grill on a balcony, deck, or patio above the ground floor of your home.
- Never** obstruct the flow of ventilation air around your gas grill housing.

Question:

The Regulator and Hose supplied with my gas grill does not fit the older LP Gas tank I've used for years. Why not?

Answer:

The U.S. Government regulates gas appliances and LP Gas tanks. When regulations are changed the LP Gas tank fittings are altered to insure compliance. If your LP Gas tank does not fit the Regulator and Hose supplied with your new grill, the tank is outdated and must be replaced. Note: Effective April 1, 2002 all LP Gas tanks sold must include an "OPD" Overfill Prevention Device. The OPD tanks are identified by their triangular-shaped valve wheel. This internal device prevents the LP Gas tank from being overfilled. Tanks without an OPD valve can not be refilled.

Question:

What causes grill parts to rust and what effect does it have on my grill?

Answer:

Rusting is a natural oxidation process and will not affect the short term performance of your grill.

To slow the rusting process on Cooking Grids, we recommend greasing the grids before and after each cookout. Use a brush to apply a thin layer of cooking oil or vegetable shortening onto each grid. We do not suggest spray type oils unless they are specified for high-temperature cooking. If your Cooking Grids are Porcelain coated, be sure to coat the entire cooking surface including edges and any areas with chipped porcelain.

Routine care and maintenance is required to preserve the appearance and corrosion resistance of stainless steel. The fact is stainless steel can corrode, rust and discolor under certain conditions. Rust is caused when regular steel particles in the atmosphere become attached to the stainless steel surface. Steel particles can also become attached to your grill if you use steel wool or stiff wire brushes to clean the grill instead of non-abrasive cloth, sponge or nylon cleaning tools. In coastal areas rust pits can develop on stainless surfaces that cannot be fully removed. Bleach and other chlorine based solutions used for household and pool cleaning can also cause corrosion to stainless steel.

Weathering, extreme heat, smoke from cooking and machine oils used in the manufacturing process of stainless steel can cause stainless steel to turn tan in color. Although there are many factors which can affect the surface appearance of stainless steel, they do not affect the integrity of the steel or the performance of the grill. To help maintain the finish of stainless steel follow these cleaning procedures for the best results:

After every use (after your grill has cooled down), wipe stainless surfaces with a soft, soapy cloth or sponge then rinse with water. Be sure to remove all food particles, sauces or marinades from stainless steel because these can be highly acidic and damaging to stainless surfaces.

Never use abrasive cleaners, scrubbers or stiff wire brushes of any type on your grill. Use a heat resistant Stainless Steel Cleaner and rub or wipe in the direction of the stainless steel grain or polish lines. Do not polish against the grain.

You may also review FAQ's, Troubleshooting and Care & Maintenance Tips online at www.grandhall.com.

Grand Hall Limited Warranty

Grand Hall will warrant to the ORIGINAL PURCHASER of this product that it will be free of defects in material and workmanship for set periods below from the date of purchase when used under normal outdoor use and correct assembly:

Cooking Grids and SS Burners - 5 Year Limited Warranty(No rust through or burn through)

Infrared Burner - 3 Year Limited Warranty

Flame Tamers, Valves, and Plastic Components - 2 Year Limited Warranty

Electronic Components - 1 Year Limited Warranty

Grill Head and Grease Tray - 10 Year Limited Warranty

All remaining parts - 2 Year Limited Warranty

Grand Hall will require reasonable proof of your date of purchase. Therefore, you should send in the owner registration card or register online at www.grandhall.com. Save your receipt in case it is required as proof of purchase.

This Limited Warranty is limited to replacement of parts at Grand Hall's option that proved to be defective under normal use and service.

Grand Hall may require the return of defective parts for examination before issuing replacement parts. If you are required to return defective parts, shipping charges must be prepaid. No returns will be accepted without prior authorization from Grand Hall.

Upon examination and to Grand Hall's satisfaction, if the original part is proven defective, Grand Hall may approve your claim and elect to replace such parts without charge. You will be charged for shipping and handling of the replacement parts.

This Warranty does not cover any failures or operating difficulties due to accident, abuse, misuse, alteration, misapplication, vandalism, improper installation, maintenance, operation or service, as set out in the Operator's Manual.

This Warranty does not cover cosmetic wear and tear such as scratches, dents, corrosion or discoloration caused by weather, heat, chemicals, paint loss, or surface rust. Deterioration or damage due to severe weather conditions such as hail, hurricanes, earthquakes, tsunamis, tornadoes, Act of God or terrorism is not covered by this Limited Warranty.

To Obtain Warranty:

Call 1-800-474-5587

Monday-Friday 8AM-4:30PM PST

Warranty Restrictions:

- This Warranty is non-transferable and is void if product is used for commercial or rental purposes.
- This Warranty applies only when the product is used in the United States or Canada.
- This Warranty gives you specific legal rights, and you may also have other rights which vary from state to state.
- We will only provide coverage to units purchased at authorized retailers.

Manufacturer:

Grand Hall Enterprise Co., Ltd.

9th Fl., No. 298, Rueiguang Rd., Neihu,

Taipei, Taiwan (114)